

PXI Express™

NI PXIe-1075 User Manual

Worldwide Technical Support and Product Information

ni.com

Worldwide Offices

Visit ni.com/niglobal to access the branch office websites, which provide up-to-date contact information, support phone numbers, email addresses, and current events.

National Instruments Corporate Headquarters

11500 North Mopac Expressway Austin, Texas 78759-3504 USA Tel: 512 683 0100

For further support information, refer to the *NI Services* appendix. To comment on NI documentation, refer to the NI website at ni.com/info and enter the Info Code `feedback`.

© 2008–2017 National Instruments. All rights reserved.

Legal Information

Limited Warranty

This document is provided 'as is' and is subject to being changed, without notice, in future editions. For the latest version, refer to ni.com/manuals. NI reviews this document carefully for technical accuracy; however, NI MAKES NO EXPRESS OR IMPLIED WARRANTIES AS TO THE ACCURACY OF THE INFORMATION CONTAINED HEREIN AND SHALL NOT BE LIABLE FOR ANY ERRORS.

NI warrants that its hardware products will be free of defects in materials and workmanship that cause the product to fail to substantially conform to the applicable NI published specifications for one (1) year from the date of invoice.

For a period of ninety (90) days from the date of invoice, NI warrants that (i) its software products will perform substantially in accordance with the applicable documentation provided with the software and (ii) the software media will be free from defects in materials and workmanship.

If NI receives notice of a defect or non-conformance during the applicable warranty period, NI will, in its discretion: (i) repair or replace the affected product, or (ii) refund the fees paid for the affected product. Repaired or replaced Hardware will be warranted for the remainder of the original warranty period or ninety (90) days, whichever is longer. If NI elects to repair or replace the product, NI may use new or refurbished parts or products that are equivalent to new in performance and reliability and are at least functionally equivalent to the original part or product.

You must obtain an RMA number from NI before returning any product to NI. NI reserves the right to charge a fee for examining and testing Hardware not covered by the Limited Warranty.

This Limited Warranty does not apply if the defect of the product resulted from improper or inadequate maintenance, installation, repair, or calibration (performed by a party other than NI); unauthorized modification; improper environment; use of an improper hardware or software key; improper use or operation outside of the specification for the product; improper voltages; accident, abuse, or neglect; or a hazard such as lightning, flood, or other act of nature.

THE REMEDIES SET FORTH ABOVE ARE EXCLUSIVE AND THE CUSTOMER'S SOLE REMEDIES, AND SHALL APPLY EVEN IF SUCH REMEDIES FAIL OF THEIR ESSENTIAL PURPOSE.

EXCEPT AS EXPRESSLY SET FORTH HEREIN, PRODUCTS ARE PROVIDED "AS IS" WITHOUT WARRANTY OF ANY KIND AND NI DISCLAIMS ALL WARRANTIES, EXPRESSED OR IMPLIED, WITH RESPECT TO THE PRODUCTS, INCLUDING ANY IMPLIED WARRANTIES OF MERCHANTABILITY, FITNESS FOR A PARTICULAR PURPOSE, TITLE OR NON-INFRINGEMENT, AND ANY WARRANTIES THAT MAY ARISE FROM USAGE OF TRADE OR COURSE OF DEALING. NI DOES NOT WARRANT, GUARANTEE, OR MAKE ANY REPRESENTATIONS REGARDING THE USE OF OR THE RESULTS OF THE USE OF THE PRODUCTS IN TERMS OF CORRECTNESS, ACCURACY, RELIABILITY, OR OTHERWISE. NI DOES NOT WARRANT THAT THE OPERATION OF THE PRODUCTS WILL BE UNINTERRUPTED OR ERROR FREE.

In the event that you and NI have a separate signed written agreement with warranty terms covering the products, then the warranty terms in the separate agreement shall control.

Copyright

Under the copyright laws, this publication may not be reproduced or transmitted in any form, electronic or mechanical, including photocopying, recording, storing in an information retrieval system, or translating, in whole or in part, without the prior written consent of National Instruments Corporation.

National Instruments respects the intellectual property of others, and we ask our users to do the same. NI software is protected by copyright and other intellectual property laws. Where NI software may be used to reproduce software or other materials belonging to others, you may use NI software only to reproduce materials that you may reproduce in accordance with the terms of any applicable license or other legal restriction.

End-User License Agreements and Third-Party Legal Notices

You can find end-user license agreements (EULAs) and third-party legal notices in the following locations:

- Notices are located in the <National Instruments>_Legal Information and <National Instruments> directories.
- EULAs are located in the <National Instruments>\Shared\MDF\Legal\license directory.
- Review <National Instruments>_Legal Information.txt for information on including legal information in installers built with NI products.

U.S. Government Restricted Rights

If you are an agency, department, or other entity of the United States Government ("Government"), the use, duplication, reproduction, release, modification, disclosure or transfer of the technical data included in this manual is governed by the Restricted Rights provisions under Federal Acquisition Regulation 52.227-14 for civilian agencies and Defense Federal Acquisition Regulation Supplement Section 252.227-7014 and 252.227-7015 for military agencies.

Trademarks

Refer to the *NI Trademarks and Logo Guidelines* at ni.com/trademarks for more information on NI trademarks.

ARM, Keil, and μ Vision are trademarks or registered of ARM Ltd or its subsidiaries.

LEGO, the LEGO logo, WEDO, and MINDSTORMS are trademarks of the LEGO Group.

TETRIX by Pitsco is a trademark of Pitsco, Inc.

FIELDBUS FOUNDATION™ and FOUNDATION™ are trademarks of the Fieldbus Foundation.

EtherCAT® is a registered trademark of and licensed by Beckhoff Automation GmbH.

CANopen® is a registered Community Trademark of CAN in Automation e.V.

DeviceNet™ and EtherNet/IP™ are trademarks of ODVA.

Go!, SensorDAQ, and Vernier are registered trademarks of Vernier Software & Technology. Vernier Software & Technology and vernier.com are trademarks or trade dress.

Xilinx is the registered trademark of Xilinx, Inc.

Taptite and Trilobular are registered trademarks of Research Engineering & Manufacturing Inc.

FireWire® is the registered trademark of Apple Inc.

Linux® is the registered trademark of Linus Torvalds in the U.S. and other countries.

Handle Graphics®, MATLAB®, Simulink®, Stateflow®, and xPC TargetBox® are registered trademarks, and Simulink Coder™, TargetBox™, and Target Language Compiler™ are trademarks of The MathWorks, Inc.

Tektronix®, Tek, and Tektronix, Enabling Technology are registered trademarks of Tektronix, Inc.

The Bluetooth® word mark is a registered trademark owned by the Bluetooth SIG, Inc.

The ExpressCard™ word mark and logos are owned by PCMCIA and any use of such marks by National Instruments is under license.

The mark LabWindows is used under a license from Microsoft Corporation. Windows is a registered trademark of Microsoft Corporation in the United States and other countries.

Other product and company names mentioned herein are trademarks or trade names of their respective companies.

Members of the National Instruments Alliance Partner Program are business entities independent from NI and have no agency, partnership, or joint-venture relationship with NI.

Patents

For patents covering NI products/technology, refer to the appropriate location: **Help»Patents** in your software, the `patents.txt` file on your media, or the *National Instruments Patent Notice* at ni.com/patents.

Export Compliance Information

Refer to the *Export Compliance Information* at ni.com/legal/export-compliance for the NI global trade compliance policy and how to obtain relevant HTS codes, ECCNs, and other import/export data.

WARNING REGARDING USE OF NATIONAL INSTRUMENTS PRODUCTS

YOU ARE ULTIMATELY RESPONSIBLE FOR VERIFYING AND VALIDATING THE SUITABILITY AND RELIABILITY OF THE PRODUCTS WHENEVER THE PRODUCTS ARE INCORPORATED IN YOUR SYSTEM OR APPLICATION, INCLUDING THE APPROPRIATE DESIGN, PROCESS, AND SAFETY LEVEL OF SUCH SYSTEM OR APPLICATION.

PRODUCTS ARE NOT DESIGNED, MANUFACTURED, OR TESTED FOR USE IN LIFE OR SAFETY CRITICAL SYSTEMS, HAZARDOUS ENVIRONMENTS OR ANY OTHER ENVIRONMENTS REQUIRING FAIL-SAFE PERFORMANCE, INCLUDING IN THE OPERATION OF NUCLEAR FACILITIES; AIRCRAFT NAVIGATION; AIR TRAFFIC CONTROL SYSTEMS; LIFE SAVING OR LIFE SUSTAINING SYSTEMS OR SUCH OTHER MEDICAL DEVICES; OR ANY OTHER APPLICATION IN WHICH THE FAILURE OF THE PRODUCT OR SERVICE COULD LEAD TO DEATH, PERSONAL INJURY, SEVERE PROPERTY DAMAGE OR ENVIRONMENTAL HARM (COLLECTIVELY, "HIGH-RISK USES"). FURTHER, PRUDENT STEPS MUST BE TAKEN TO PROTECT AGAINST FAILURES, INCLUDING PROVIDING BACK-UP AND SHUT-DOWN MECHANISMS. NI EXPRESSLY DISCLAIMS ANY EXPRESS OR IMPLIED WARRANTY OF FITNESS OF THE PRODUCTS OR SERVICES FOR HIGH-RISK USES.

Contents

About This Manual

Related Documentation	vii
-----------------------------	-----

Chapter 1

Getting Started

Unpacking.....	1-1
What You Need to Get Started	1-1
Key Features	1-2
Chassis Description	1-4
Optional Equipment.....	1-5
EMC Filler Panels	1-5
Rack Mount Kit	1-5
Slot Blockers.....	1-5
NI PXIe-1075 Chassis Backplane Overview.....	1-6
Interoperability with CompactPCI.....	1-6
System Controller Slot.....	1-6
Hybrid Peripheral Slots	1-7
PXI Express Peripheral Slots.....	1-7
System Timing Slot	1-8
PXI Local Bus	1-9
PXI Trigger Bus.....	1-9
System Reference Clock.....	1-10
PXIe_SYNC_CTRL	1-12

Chapter 2

Installation and Configuration

Safety Information	2-1
Chassis Cooling Considerations	2-2
Providing Adequate Clearance	2-2
Chassis Ambient Temperature Definition	2-3
Setting Fan Speed	2-4
Installing Filler Panels	2-4
Installing Slot Blockers	2-4
Rack Mounting	2-4
Connecting Safety Ground	2-4
Connecting to Power Source	2-5
Installing a PXI Express System Controller	2-5
Installing Peripheral Modules.....	2-7
Power Inhibit Switch LED Indicator	2-8
Remote Voltage Monitoring and Control	2-9
Inhibit Mode Switch	2-10
PXI_CLK10 Rear Connectors	2-11

Contents

PXI Express System Configuration with MAX.....2-11
 PXI-1 System Configuration2-12
 Trigger Configuration in MAX.....2-12
 PXI Trigger Bus Routing.....2-13
Using System Configuration and Initialization Files.....2-13

Chapter 3
Maintenance

Service Interval3-1
Preparation3-1
Cleaning3-1
 Interior Cleaning3-1
 Exterior Cleaning3-2
 Cleaning the Fan Filters3-2
Resetting the AC Mains Circuit Breaker3-2
Replacing the Modular Power Supply Shuttle.....3-3
 Removal3-3
 Installation3-4
 Configuration3-4
 Connecting Safety Ground.....3-4
 Connecting to Power Source.....3-4

Appendix A
Specifications

Appendix B
Pinouts

Appendix C
NI Services

Glossary

Index

About This Manual

The *NI PXIe-1075 User Manual* describes the features of the NI PXIe-1075 chassis and contains information about configuring the chassis, installing the modules, and operating the chassis.

Related Documentation

The following documents contain information that you might find helpful as you read this manual:

- IEEE 1101.1-1991, *IEEE Standard for Mechanical Core Specifications for Microcomputers Using IEC 603-2 Connectors*
- IEEE 1101.10, *IEEE Standard for Additional Mechanical Specifications for Microcomputers Using IEEE 1101.1 Equipment Practice*
- *PICMG EXP.0 R1.0 CompactPCI Express Specification*, PCI Industrial Computers Manufacturers Group
- *PCI Express Base Specification*, Revision 1.1, PCI Special Interest Group
- *PXI-5 PXI Express Hardware Specification*, Revision 2.0, PXI Systems Alliance

Getting Started

This chapter describes the key features of the NI PXIe-1075 chassis and lists the kit contents and optional equipment you can order from National Instruments.

Unpacking

Carefully inspect the shipping container and the chassis for damage. Check for visible damage to the metal work. Check to make sure all handles, hardware, and switches are undamaged. Inspect the inner chassis for any possible damage, debris, or detached components. If damage appears to have been caused during shipment, file a claim with the carrier. Retain the packing material for possible inspection and/or reshipment.

What You Need to Get Started

The NI PXIe-1075 chassis kit contains the following items:

- NI PXIe-1075 chassis
- Filler panels
- AC power cable—refer to Table 1-1 for AC power cables
- NI PXIe-1075 User Manual*
- Software media with *PXI Platform Services 2.0* or higher
- Read Me First: Safety and Electromagnetic Compatibility*
- Chassis number labels

Table 1-1. AC Power Cables

Power Cable	Reference Standards
Standard 120 V, 15 A (USA)	NEMA 5-15 (gray color)
Switzerland 220 V	SEV
Australia 240 V	AS C112

Table 1-1. AC Power Cables (Continued)

Power Cable	Reference Standards
Universal Euro 230 V	CEE (7), II, IV, VII IEC83
North America 120 V, 15 A	NEMA 5-15 (gray color)
United Kingdom 230 V	BS 1363/IEC83
Japan 100 V, 15 A	JIS C8303 (gray color)

For 100 to 120 VAC installation, use the NI cable part numbers listed in Table 1-2, which are rated for 125 V/15 A.

Table 1-2. AC Power Cable Part Numbers for 100 to 120 VAC Installation

Country	NI Part Number
North America	763830-01
Japan	763841-01



Note NI PXI-1075 chassis ordered in North America or Japan ship with the proper cables by default.

If you are missing any of the items listed in Table 1-1 or Table 1-2, or if you have the incorrect AC power cable, contact National Instruments.

Key Features

The NI PXIe-1075 chassis combines a high-performance 18-slot PXI Express backplane with a high-output power supply and a structural design that has been optimized for maximum usability in a wide range of applications. The chassis’ modular design ensures a high level of maintainability, resulting in a very low mean time to repair (MTTR). The NI PXIe-1075 chassis fully complies with the *PXI-5 PXI Express Hardware Specification*, offering advanced timing and synchronization features.

The key features of the NI PXIe-1075 chassis include the following:

High Performance for Instrumentation Requirements

- Up to 1 GB/s (single direction) per PXI Express slot dedicated bandwidth (x4 PCIe)
- 38 W per slot cooling meets increased PXIe cooling requirements

- Low-jitter internal 10 MHz reference clock for PXI slots with ± 25 ppm stability
- Low-jitter internal 100 MHz reference clock for PXIe slots with ± 25 ppm stability
- 8 hybrid slots for supporting existing PXI instruments
- Quiet operation for 0 °C to 30 °C at 43.6 dBA
- Variable speed fan controller optimizes cooling and acoustic emissions
- Remote power-inhibit control
- Complies with PXI and CompactPCI Specifications

High Reliability

- 0 to 55 °C extended temperature range
- Power supply, temperature, and fan monitoring
- HALT tested for increased reliability
- Field replaceable power supply shuttle

Multi-Chassis Support

- PXIe System Timing Slot for tight synchronization across chassis
- Rear CLK10 I/O connectors
- Switchless CLK10 routing

Optional Features

- Front and rear rack-mount kits
- Replacement power supply shuttle
- EMC filler panels
- Slot blockers for improved cooling performance
- Factory installation services

Chassis Description

Figures 1-1 and 1-2 show the key features of the NI PXIe-1075 chassis front and back panels. Figure 1-1 shows the front view of the NI PXIe-1075. Figure 1-2 shows the rear view of the NI PXIe-1075.

Figure 1-1. Front View of the NI PXIe-1075 Chassis

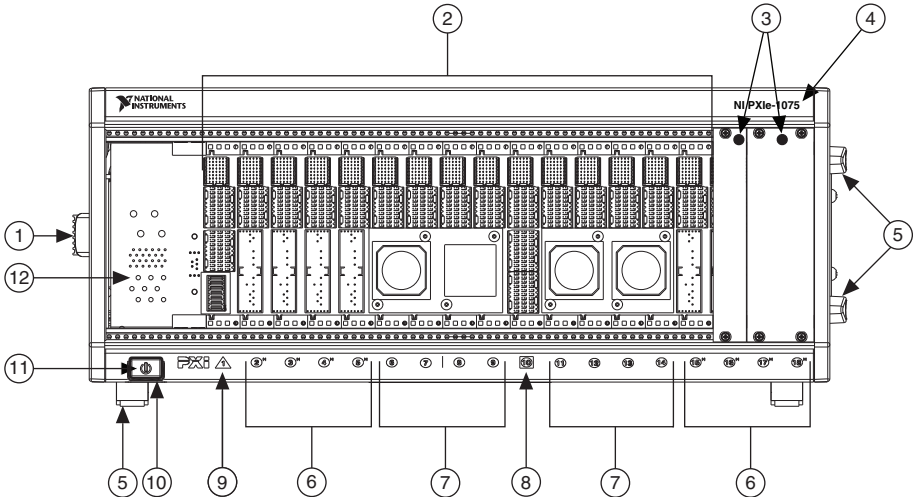

- | | |
|--|--------------------------------------|
| 1 Chassis Carry Handle | 7 PXI Express Peripheral Slots (8x) |
| 2 Backplane Connectors | 8 PXI Express System Timing Slot |
| 3 PXI Filler Panels | 9 PXI Express System Controller Slot |
| 4 Chassis Model Name | 10 Power Inhibit Switch |
| 5 Removable Feet | 11 Power Inhibit Switch LED |
| 6 PXI Express Hybrid Peripheral Slots (8x) | 12 System Controller Expansion Slots |

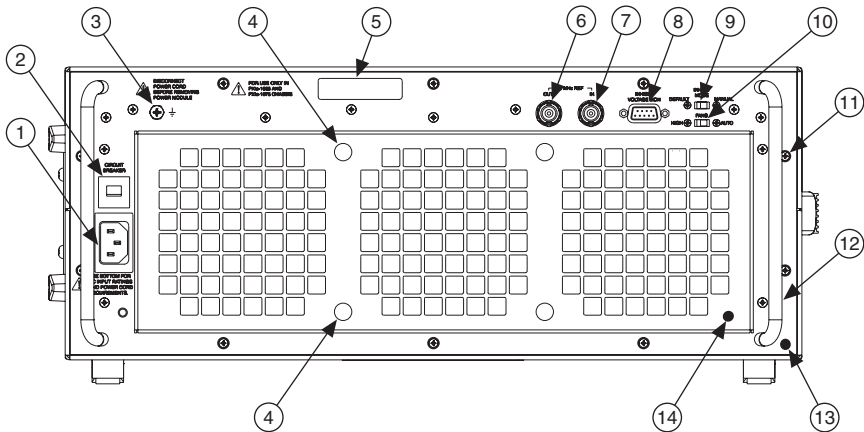
Figure 1-2. Rear View of the NI PXIe-1075 Chassis

- | | |
|---------------------------------|---|
| 1 Universal AC Input | 8 Remote Inhibit and Voltage Monitoring Connector |
| 2 Push-Reset Circuit Breaker | 9 Inhibit Mode Selector Switch |
| 3 Chassis Ground Screw | 10 Fan Speed Selector Switch |
| 4 Air Filter Retainer Screws | 11 Power Supply Shuttle Mounting Screws (10x) |
| 5 Power Supply Shuttle ID Label | 12 Power Supply Shuttle Handle (2x) |
| 6 10 MHz REF OUT BNC | 13 Power Supply Shuttle |
| 7 10 MHz REF IN BNC | 14 Air Filter Retainer |

Optional Equipment

Contact National Instruments to order the following options for the NI PXIe-1075 chassis.

EMC Filler Panels

Optional EMC filler panel kits are available from National Instruments.

Rack Mount Kit

There are two optional kits for mounting the PXIe-1075 chassis into a rack. The first option is a pair of mounting brackets for use on the front of the chassis. The second option is a rear rack mount kit. The rear rack mount kit differs from the front kit to allow for easier installation into the rack. For more information, refer to Figure A-3, [NI Chassis Rack Mount Kit Components](#).

Slot Blockers

Optional slot blocker kits are available from National Instruments for improved thermal performance when all slots are not used.

NI PXIe-1075 Chassis Backplane Overview

This section provides an overview of the backplane features for the NI PXIe-1075 chassis.

Interoperability with CompactPCI

The design of the NI PXIe-1075 provides you the flexibility to use the following devices in a single PXI Express chassis:

- PXI Express compatible products
- CompactPCI Express compatible 4-Link system controller products
- CompactPCI Express compatible Type-2 peripheral products
- PXI peripheral products
- Standard CompactPCI peripheral products

Refer to Figure 1-3 for an overview of the NI PXIe-1075 architecture.

Figure 1-3. NI PXIe-1075 Backplane Architecture

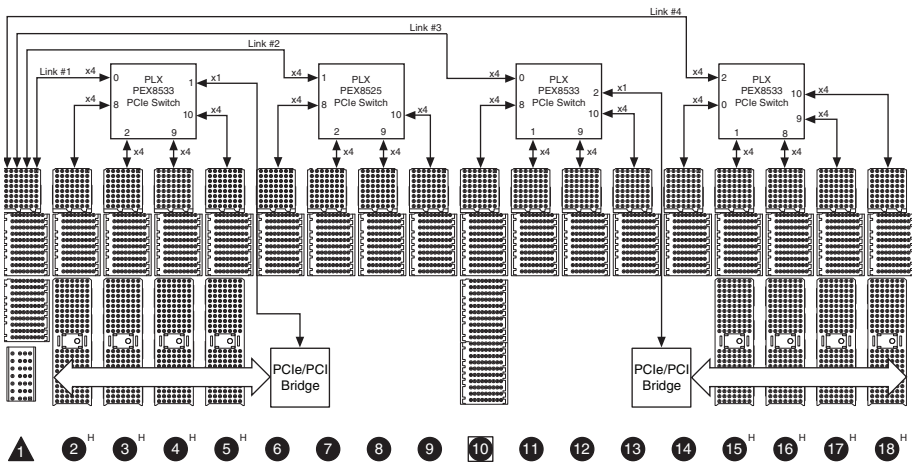

System Controller Slot

The system controller slot is Slot 1 of the chassis and is a 4-Link configuration system slot as defined by the CompactPCI Express and PXI Express specifications. It has three system controller expansion slots for system controller modules that are wider than one slot. These slots allow the system controller to expand to the left to prevent the system controller from using peripheral slots.

The backplane routes each of the system slots' x4 PCI Express (PCIe) links to a PCIe switch. The four (4) PCIe switches have x4 PCIe links routed to each peripheral slot as well as x1 links to two (2) PCIe-to-PCI bridges providing 32-bit/33 MHz PCI busses to the hybrid slots. Refer to Figure 1-3 for the connectivity of PCIe and PCI.

By default, the system controller will control the power supply with the PS_ON# signals. A logic low on this line will turn the power supply on.



Note The Inhibit Mode switch on the rear of the chassis must be in the **Default** position for the system controller to have control of the power supply. Refer to the [Inhibit Mode Switch](#) section of Chapter 2, *Installation and Configuration*, for details about the Inhibit Mode switch.

Hybrid Peripheral Slots

The chassis provides eight hybrid peripheral slots as defined by the *PXI-5 PXI Express Hardware Specification*: slots 2 to 5 and slots 15 to 18. A hybrid peripheral slot can accept the following peripheral modules:

- A PXI Express Peripheral with x4 or x1 PCI Express link to the system slot or through a PCIe switch to the system slot.
- A CompactPCI Express Type-2 Peripheral with x4 or x1 PCI Express link to the system slot or through a PCIe switch to the system slot.
- A hybrid-compatible PXI Peripheral module that has been modified by replacing the J2 connector with an XJ4 connector installed in the upper eight rows of J2. Refer to the *PXI Express Specification* for details. The PXI Peripheral communicates through the backplane's 32-bit PCI bus.
- A CompactPCI 32-bit peripheral on the backplane's 32-bit PCI bus.

The hybrid peripheral slots provide full PXI Express functionality and 32-bit PXI functionality except for PXI Local Bus. The hybrid peripheral slot only connects to PXI Local Bus 6 left and right.

PXI Express Peripheral Slots

There are eight (8) PXI Express peripheral slots: slots 6 to 9 and 11 to 14 (=8 slots). PXI Express peripheral slots can accept the following modules:

- A PXI Express Peripheral with x4 or x1 PCI Express link to the system slot or through a PCIe switch to the system slot.
- A CompactPCI Express Type-2 Peripheral with x4 or x1 PCI Express link to the system slot or through a PCIe switch to the system slot.

System Timing Slot

The System Timing Slot is slot 10. The system timing slot will accept the following peripheral modules:

- A PXI Express System Timing Module with x4 or x1 PCI Express link to the system slot through a PCIe switch.
- A PXI Express Peripheral with x4 or x1 PCI Express link to the system slot through a PCIe switch.
- A CompactPCI Express Type-2 Peripheral with x4 or x1 PCI Express link to the system slot through a PCIe switch.

The system timing slot has 3 dedicated differential pairs (PXIe_DSTAR) connected from the TP1 and TP2 connectors to the XP3 connector for each PXI Express peripheral or hybrid peripheral slot, as well as routed back to the XP3 connector of the system timing slot as shown in Figure 1-4. The PXIe_DSTAR pairs can be used for high-speed triggering, synchronization and clocking. Refer to the *PXI Express Specification* for details.

The system timing slot also has a single-ended (PXI Star) trigger connected to every slot. Refer to Figure 1-4 for details.

The system timing slot has a pin (PXI_CLK10_IN) through which a system timing module may source a 10 MHz clock to which the backplane will phase-lock. Refer to the [System Reference Clock](#) section for details.

The system timing slot has a pin (PXIe_SYNC_CTRL) through which a system timing module can control the PXIe_SYNC100 timing. Refer to the *PXI Express Specification* and the [PXIe_SYNC_CTRL](#) section of this chapter for details.

Figure 1-4. PXIe_DSTAR and PXI Star Connectivity Diagram

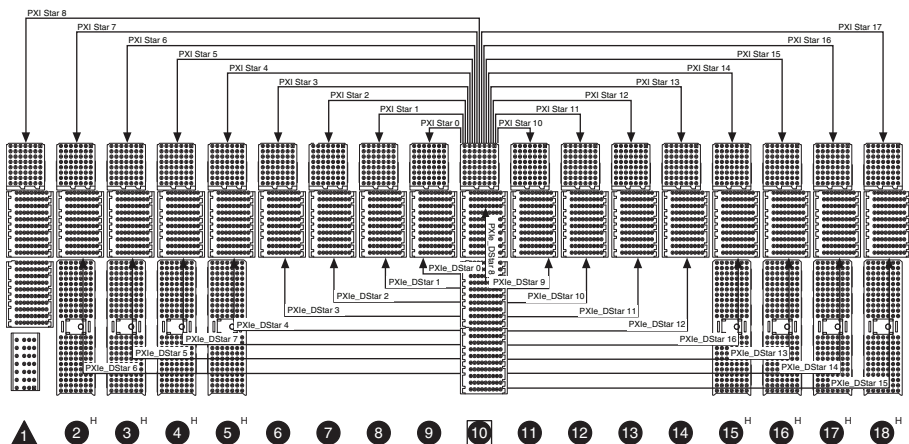

PXI Local Bus

The PXI backplane local bus is a daisy-chained bus that connects each peripheral slot with adjacent peripheral slots to the left and right.

The backplane routes PXI Local Bus 6 between adjacent PXI slots. The left local bus 6 from slot 1 is not routed anywhere and the right local bus signal from slot 18 is not routed anywhere.

Local bus signals may range from high-speed TTL signals to analog signals as high as 42 V.

Initialization software uses the configuration information specific to each adjacent peripheral module to evaluate local bus compatibility.

PXI Trigger Bus

All slots on the same PXI bus segment share eight PXI trigger lines. You can use these trigger lines in a variety of ways. For example, you can use triggers to synchronize the operation of several different PXI peripheral modules. In other applications, one module located in the system timing slot can control carefully timed sequences of operations performed on other modules in the system. Modules can pass triggers to one another, allowing precisely timed responses to asynchronous external events the system is monitoring or controlling.

The PXI trigger lines from adjacent PXI trigger bus segments can be routed in either direction across the PXI trigger bridges. Refer to Figure 1-5 for the connectivity diagram. This allows you to send trigger signals to, and receive trigger signals from, every slot in the chassis. Static trigger routing (user-specified line and directional assignments) can be configured through Measurement & Automation Explorer (MAX). Dynamic routing of triggers (automatic line assignments) is supported through certain National Instruments drivers like NI-DAQmx.



Note Although any trigger line may be routed in either direction, it cannot be routed in more than one direction at a time.

Figure 1-5. PXI Trigger Bus Connectivity Diagram

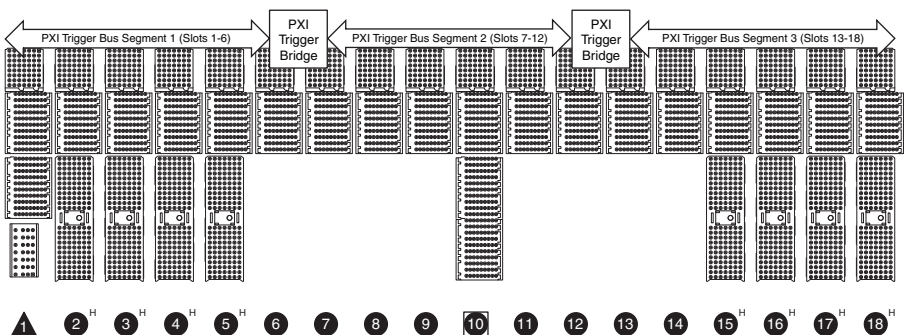

System Reference Clock

The PXIe-1075 chassis supplies PXI_CLK10, PXIe_CLK100 and PXIe_SYNC100 to every peripheral slot with an independent driver for each signal.

An independent buffer (having a source impedance matched to the backplane and a skew of less than 1 ns between slots) drives PXI_CLK10 to each peripheral slot. You can use this common reference clock signal to synchronize multiple modules in a measurement or control system.

An independent buffer drives PXIe_CLK100 to each peripheral slot. These clocks are matched in skew to less than 100 ps. The differential pair must be terminated on the peripheral with LVPECL termination for the buffer to drive PXIe_CLK100 so that when there is no peripheral or a peripheral that does not connect to PXIe_CLK100, there is no clock being driven on the pair to that slot. Refer to Figure 1-6 for a termination example.

Figure 1-6. CLK100 Termination

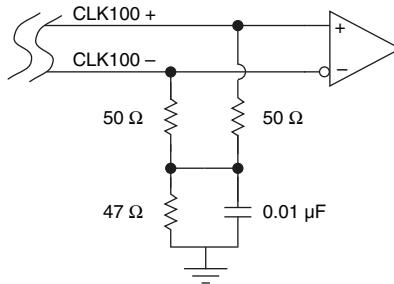

An independent buffer drives PXIe_SYNC100 to each peripheral slot. The differential pair must be terminated on the peripheral with LVPECL termination for the buffer to drive PXIe_SYNC100 so that when there is no peripheral or a peripheral that does not connect to PXIe_SYNC100, there is no SYNC100 signal being driven on the pair to that slot. Refer to Figure 1-6 for a termination example.

In summary, PXI_CLK10 is driven to every slot. PXIe_CLK100 and PXIe_SYNC100 are driven to every peripheral slot.

PXI_CLK10, PXIe_CLK100 and PXIe_SYNC100 have the default timing relationship described in Figure 1-7.

Figure 1-7. System Reference Clock Default Behavior

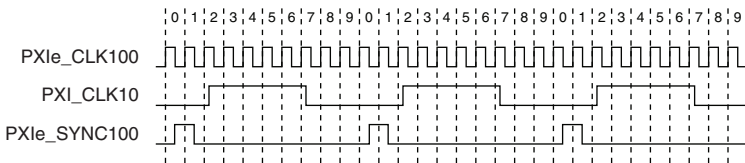

To synchronize the system to an external clock, you can drive PXI_CLK10 from an external source through the PXI_CLK10_IN pin on the System Timing Slot. Refer to Table B-5, *XP4 Connector Pinout for the System Timing Slot*, for the pinout. When a 10 MHz clock is detected on this pin, the backplane automatically phase-locks the PXI_CLK10, PXIe_CLK100, and PXIe_SYNC100 signals to this external clock and distributes these signals to the slots. Refer to Appendix A, *Specifications*, for the specification information for an external clock provided on the PXI_CLK10_IN pin of the system timing slot.

You also can drive a 10 MHz clock on the 10 MHz REF IN connector on the rear of the chassis. Refer to Figure 1-2 for the location of this connector. When a 10 MHz clock is detected on this connector, the backplane automatically phase-locks the PXI_CLK10, PXIe_CLK100, and PXIe_SYNC100 signals to this external clock and distributes these signals to the slots. Refer to Appendix A, *Specifications*, for the specification information for an external clock provided on the 10 MHz REF IN connector on the rear panel of the chassis.

If the 10 MHz clock is present on both the PXI_CLK10_IN pin of the System Timing Slot and the 10 MHz REF IN connector on the rear of the chassis, the signal on the System Timing Slot is selected. Refer to Table 1-3 which explains how the 10 MHz clocks are selected by the backplane.

Table 1-3. Backplane External Clock Input Truth Table

System Timing Slot PXI_CLK10_IN	Rear Chassis Panel 10 MHz REF IN	Backplane PXI_CLK10, PXIe_CLK100 and PXIe_SYNC100
No clock present	No clock present	Backplane generates its own clocks
No clock present	10 MHz clock present	PXI_CLK10, PXIe_CLK100 and PXIe_SYNC100 all phase-locked to Rear Chassis Panel—10 MHz REF IN
10 MHz clock present	No clock present	PXI_CLK10, PXIe_CLK100 and PXIe_SYNC100 all phase-locked to System Timing Slot—PXI_CLK10_IN
10 MHz clock present	10 MHz clock present	PXI_CLK10, PXIe_CLK100 and PXIe_SYNC100 all phase-locked to System Timing Slot—PXI_CLK10_IN

A copy of the backplane's PXI_CLK10 is exported to the 10 MHz REF OUT connector on the rear of the chassis. Refer to Figure 1-2 for the location of this connector. This clock is driven by an independent buffer. Refer to Appendix A, *Specifications*, for the specification information for the 10 MHz REF OUT signal on the rear panel of the chassis.

PXle_SYNC_CTRL

PXle_SYNC100 is by default a 10 ns pulse synchronous to PXI_CLK10. The frequency of PXle_SYNC100 is $10/n$ MHz, where n is a positive integer. The default for n is 1, giving PXle_SYNC100 a 100 ns period. However, the backplane allows n to be programmed to other integers. For instance, setting $n = 3$ gives a PXle_SYNC100 with a 300ns period while still maintaining its phase relationship to PXI_CLK10. The value for n may be set to any positive integer from 1 to 255.

The system timing slot has a control pin for PXle_SYNC100 called PXle_SYNC_CTRL for use when $n > 1$. Refer to Table B-6, *XP3 Connector Pinout for the System Timing Slot*, for system timing slot pinout. Refer to Appendix A, *Specifications*, for the PXle_SYNC_CTRL input specifications.

By default, a high-level detected by the backplane on the PXle_SYNC_CTRL pin causes a synchronous restart for the PXle_SYNC100 signal. On the next PXI_CLK10 edge the PXle_SYNC100 signal will restart. This will allow several chassis to have their PXle_SYNC100 in phase with each other. Refer to Figure 1-8 for timing details with this method.

Figure 1-8. PXle_SYNC100 at 3.33 MHz Using PXle_SYNC_CTRL as Restart

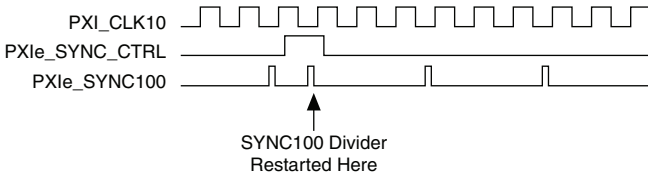

Installation and Configuration

This chapter describes how to prepare and operate the NI PXIe-1075 chassis.

Before connecting the chassis to a power source, read this chapter and the *Read Me First: Safety and Electromagnetic Compatibility* document included with your kit.

Safety Information



Caution Before undertaking any troubleshooting, maintenance, or exploratory procedure, carefully read the following caution notices.

This equipment contains voltage hazardous to human life and safety, and is capable of inflicting personal injury.

- **Chassis Grounding**—The chassis requires a connection from the premise wire safety ground to the chassis ground. The earth safety ground must be connected during use of this equipment to minimize shock hazards. Refer to the [Connecting Safety Ground](#) section for instructions on connecting safety ground.
- **Live Circuits**—Operating personnel and service personnel *must* not remove protective covers when operating or servicing the chassis. Adjustments and service to internal components must be undertaken by qualified service technicians. During service of this product, the mains connector to the premise wiring must be disconnected. Dangerous voltages may be present under certain conditions; use extreme caution.
- **Explosive Atmosphere**—Do *not* operate the chassis in conditions where flammable gases are present. Under such conditions, this equipment is unsafe and may ignite the gases or gas fumes.
- **Part Replacement**—Only service this equipment with parts that are exact replacements, both electrically and mechanically. Contact National Instruments for replacement part information. Installation of parts with those that are not direct replacements may cause harm to personnel operating the chassis. Furthermore, damage or fire may occur if replacement parts are unsuitable.
- **Modification**—Do *not* modify any part of the chassis from its original condition. Unsuitable modifications may result in safety hazards.

Chassis Cooling Considerations

The NI PXIe-1075 chassis is designed to operate on a bench or in an instrument rack. Regardless of the configuration you must provide the cooling clearances as outlined in the following sections.

Providing Adequate Clearance

The primary cooling exhaust vent for the NI PXIe-1075 is on the top of the chassis. The primary intake vent is on the rear of the chassis where the air is filtered as it enters the power supply shuttle. The secondary intake and exhaust vents are located along the sides of the chassis. Adequate clearance between the chassis and surrounding equipment or blockages must be maintained to ensure proper cooling of the chassis power supply as well as the modules plugged into the chassis. These clearances are outlined in Figure 2-1. The vent locations for the NI PXIe-1075 chassis are shown in Figure 2-2. Failure to provide these clearances may result in thermal-related failures in the chassis or modules.

Figure 2-1. NI PXIe-1075 Cooling Clearances

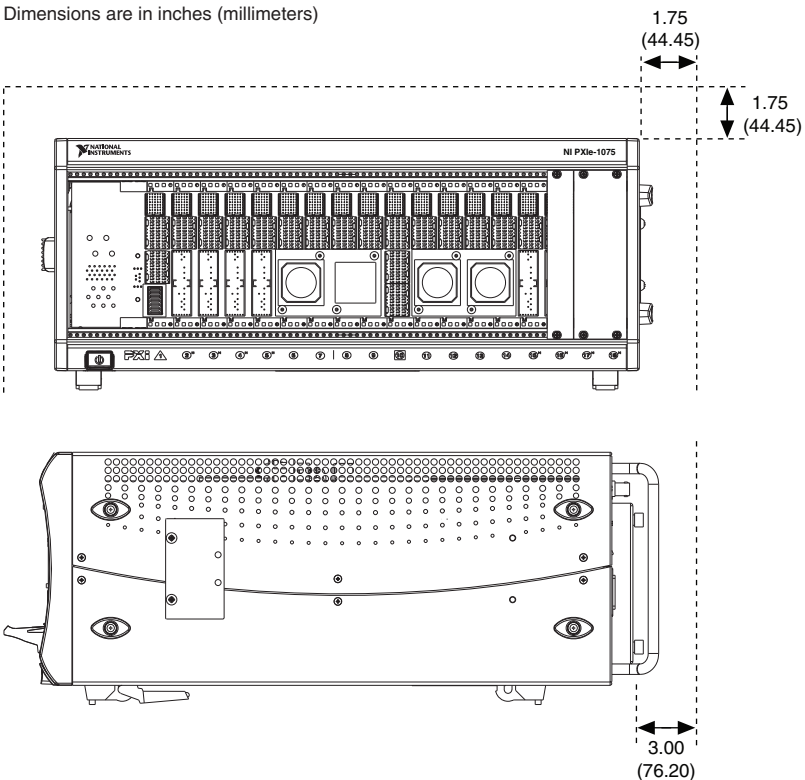
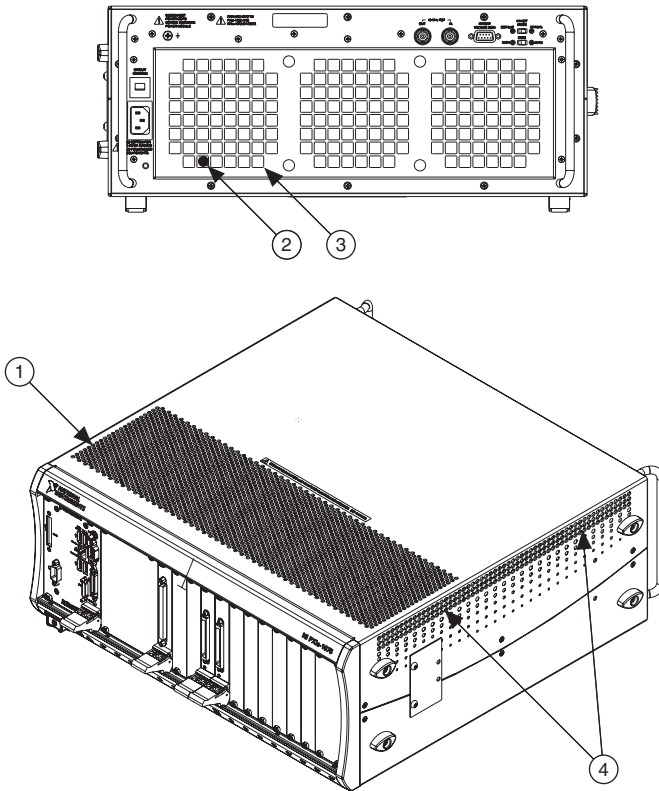

Figure 2-2. NI PXIe-1075 Vents



- | | |
|----------------------------|---|
| 1 Primary Air Exhaust Vent | 3 Primary Air Intake Vent |
| 2 Air Filter | 4 Secondary Air Intake/Exhaust Vents (both sides) |

Chassis Ambient Temperature Definition

The chassis fan control system uses intake air temperature as the input for controlling fan speeds when in Auto Fan Speed mode. Because of this, the chassis ambient temperature is defined as the temperature that exists just outside of the fan intake vents on the rear of the chassis. Note that this temperature may be higher than ambient room temperature depending on the surrounding equipment and/or blockages present. It is the user's responsibility to ensure that this ambient temperature does not exceed the rated ambient temperature as stated in Appendix A, [Specifications](#). If the temperature exceeds the stated spec the power switch LED will blink green, as discussed in the [Power Inhibit Switch LED Indicator](#) section of this chapter.

Setting Fan Speed

The fan-speed selector switch is on the rear panel of the NI PXIe-1075 chassis. Refer to Figure 1-2, *Rear View of the NI PXIe-1075 Chassis*, to locate the fan-speed selector switch. Select **High** for maximum cooling performance or **Auto** for improved acoustic performance. When set to **Auto**, the fan speed is determined by chassis intake air temperature.

Installing Filler Panels

To maintain proper module cooling performance, install filler panels (provided with the chassis) in unused or empty slots. Secure with the captive mounting screws provided.

Installing Slot Blockers

The cooling performance of the chassis can be improved by installing optional slot blockers. Refer to ni.com for more details.

Rack Mounting

Rack mount applications require the optional rack mount kits available from National Instruments. Refer to the instructions supplied with the rack mount kits to install your NI PXIe-1075 chassis in an instrument rack. Refer to Figure A-3, *NI Chassis Rack Mount Kit Components*.



Note You may want to remove the feet from the NI PXIe-1075 chassis when rack mounting. To do so, remove the screws holding the feet in place.

Connecting Safety Ground



Caution The NI PXIe-1075 chassis are designed with a three-position NEMA 5-15 style plug for the U.S. that connects the ground line to the chassis ground. To minimize shock hazard, make sure the electrical power outlet you use to power the chassis has an appropriate earth safety ground.

If your power outlet does not have an appropriate ground connection, you must connect the premise safety ground to the chassis grounding screw located on the rear panel. Refer to Figure 1-2, *Rear View of the NI PXIe-1075 Chassis*, to locate the chassis grounding screw. To connect the safety ground, complete the following steps:

1. Connect a 16 AWG (1.3 mm) wire to the chassis grounding screw using a grounding lug. The wire must have green insulation with a yellow stripe or must be noninsulated (bare).
2. Attach the opposite end of the wire to permanent earth ground using toothed washers or a toothed lug.

Connecting to Power Source



Caution Do *not* install modules prior to performing the following power-on test.

To completely remove power, you *must* disconnect the AC power cable.

Attach input power through the rear AC inlet using the appropriate AC power cable supplied. Refer to Figure 1-2, [Rear View of the NI PXIe-1075 Chassis](#), to locate the AC inlet.

The Inhibit Mode switch allows you to power on the chassis or place it in standby mode. Set the Inhibit Mode switch on the back of the chassis to the **Manual** position. Observe that all fans become operational and the power switch LED is a steady green. Switching the Inhibit Mode switch to the **Default** position allows the system controller to control the power supply.

Installing a PXI Express System Controller

This section contains general installation instructions for installing a PXI Express system controller in a NI PXIe-1075 chassis. Refer to your PXI Express system controller user manual for specific instructions and warnings. To install a system controller, complete the following steps:

1. Inspect the slot 1 pins on the chassis backplane for any bending or damage prior to installation.
2. Connect the AC power source to the PXI Express chassis before installing the system controller. The AC power cord grounds the chassis and protects it from electrical damage while you install the system controller.
3. Install the system controller into the system controller slot (slot 1, indicated by the red card guides) by first placing the system controller PCB into the front of the card guides (top and bottom). Slide the system controller to the rear of the chassis, making sure that the injector/ejector handle is pushed down as shown in Figure 2-3.

Figure 2-3. Installing a PXIe System Controller

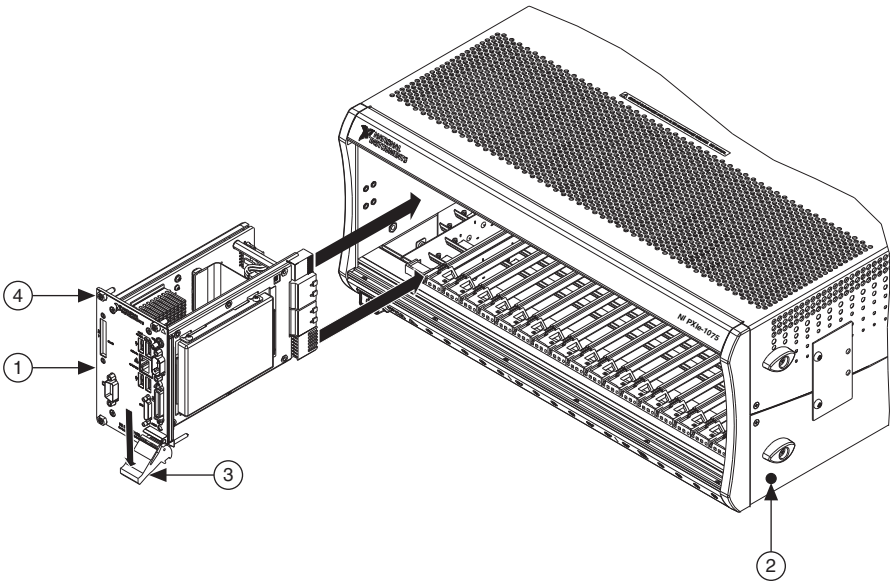

- | | | | |
|---|----------------------------------|---|--|
| 1 | NI PXI Express System Controller | 3 | Injector/Ejector Handle |
| 2 | NI PXIe-1075 Chassis | 4 | System Controller Front Panel Mounting Screws (4x) |

4. When you begin to feel resistance, pull up on the injector/ejector handle to seat the system controller fully into the chassis frame. Secure the system controller front panel to the chassis using the system controller front-panel mounting screws.
5. Connect the keyboard, mouse, and monitor to the appropriate connectors. Connect devices to ports as required by your system configuration.
6. Power on the chassis. Verify that the system controller boots. If the system controller does not boot, refer to your system controller user manual.

Figure 2-4 shows a PXI Express system controller installed in the system controller slot of a NI PXIe-1075 chassis. You can place CompactPCI, CompactPCI Express, PXI, or PXI Express modules in other slots depending on the slot type.

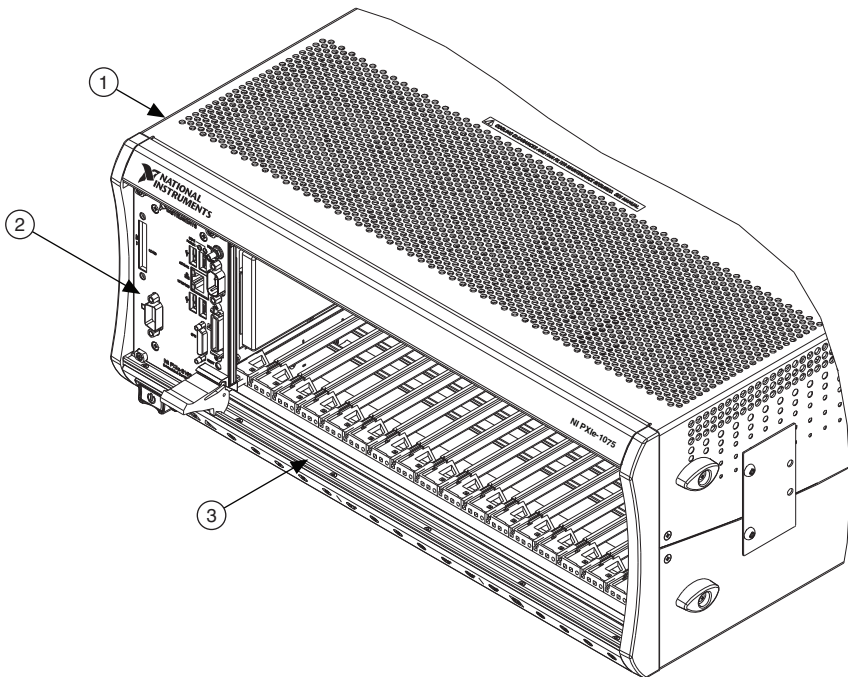
Figure 2-4. NI PXI Express System Controller Installed in a NI PXIe-1075 Chassis

1	2	3
NI PXIe-1075 Chassis	NI PXIe System Controller	Injector/Ejector Rail

Installing Peripheral Modules



Caution The NI PXIe-1075 chassis has been designed to accept a variety of peripheral module types in different slots. To prevent damage to the chassis, ensure that the peripheral module is being installed into a slot designed to accept it. Refer to Chapter 1, *Getting Started*, for a description of the various slot types.

This section contains general installation instructions for installing a peripheral module in a NI PXIe-1075 chassis. Refer to your peripheral module user manual for specific instructions and warnings. To install a module, complete the following steps:

1. Inspect the slot for any physical damage or bent pins before installing the peripheral module.
2. Connect the AC power source to the PXI Express chassis before installing the module. The AC power cord grounds the chassis and protects it from electrical damage while you install the module.
3. Ensure that the chassis is powered off.

4. Install a module into a chassis slot by first placing the module card PCB into the front of the card guides (top and bottom), as shown in Figure 2-5. Slide the module to the rear of the chassis, making sure that the injector/ejector handle is pushed down as shown in Figure 2-5.
5. When you begin to feel resistance, push up on the injector/ejector handle to fully seat the module into the chassis frame. Secure the module front panel to the chassis using the module front-panel mounting screws.

Figure 2-5. Installing PXI, PXI Express, or CompactPCI Peripheral Modules

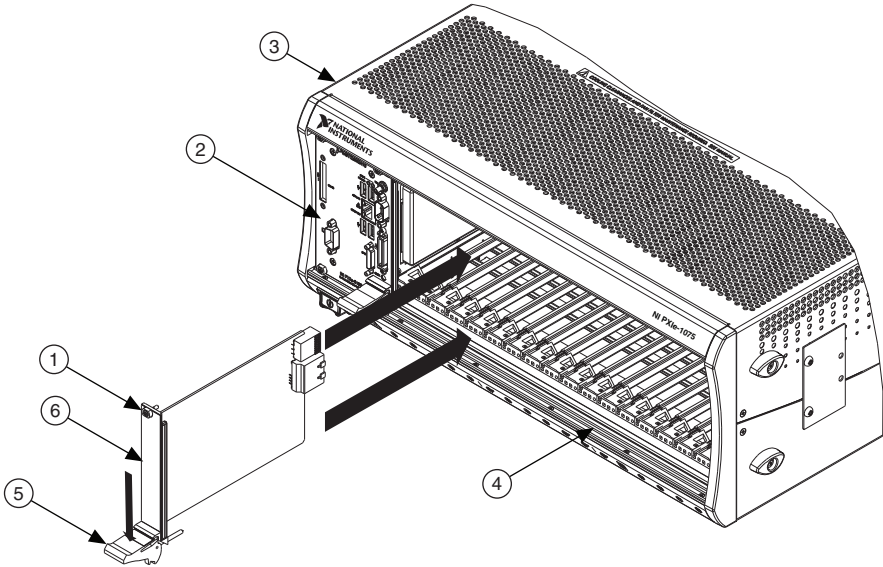

- | | |
|--|---------------------------------|
| 1 Peripheral Module Front Panel Mounting Screws (2x) | 4 Injector/Ejector Rail |
| 2 NI PXI Express System Controller | 5 Injector/Ejector Handle |
| 3 NI PXIe-1075 Chassis | 6 PXI Express Peripheral Module |

Power Inhibit Switch LED Indicator

The chassis power inhibit switch has an integrated LED. Refer to Figure 1-1, [Front View of the NI PXIe-1075 Chassis](#), for the location of both the Power Inhibit switch and the LED. This LED indicates one of four different conditions:

- If the inhibit switch LED is steady green (not flashing), the chassis is powered on and operating normally.
- If the inhibit switch LED is flashing green, the air-intake temperature has exceeded the chassis operating range.

- If the inhibit switch LED is flashing red, the power supply outputs are not within voltage regulation requirements.
- If the inhibit switch LED is steady red, the system fans or power supply fan has failed. The remaining fans will automatically be driven high.



Note If two system fans or both of the power supply fans fail the chassis will shut down automatically, preventing the chassis and modules from damage due to overheating.

Remote Voltage Monitoring and Control

The NI PXIe-1075 chassis supports remote voltage monitoring and inhibiting through a female 9-pin D-SUB (DB-9) connector located on the rear panel as shown in Figure 1-2, [Rear View of the NI PXIe-1075 Chassis](#). Table 2-1 shows the pinout of the 9-pin D-SUB (DB-9) connector.

Table 2-1. Remote Inhibit and Voltage Monitoring Connector Pinout

DB-9 Pin	Signal
1	Logic Ground
2	+5 VDC
3	Reserved
4	+3.3 VDC
5	Inhibit (Active Low)
6	+12 VDC
7	Reserved
8	-12 VDC
9	Logic Ground



Caution When connecting digital voltmeter probes to the rear 9-pin D-SUB (DB-9) connector, be careful not to short the probe leads together. Doing so could damage the power supply.

You can use a digital voltmeter to ensure all voltage levels in the NI PXIe-1075 chassis are within the allowable limits. Referring to Table 2-2, connect one lead of the voltmeter to a supply pin on the remote voltage monitoring connector (9-pin D-SUB) on the rear panel. Refer to Table 2-1 for a pinout diagram of the remote voltage monitoring connector. Connect the reference lead of the voltmeter to one of the ground pins. Compare each voltage reading to the values listed in Table 2-2.



Note Use the rear-panel 9-pin D-SUB connector to check voltages only. Do not use the connector to supply power to external devices.

Table 2-2. Power Supply Voltages at Voltage Monitoring Connector (DB-9)

Pin	Supply	Acceptable Voltage Range
2	+5 V	4.75 to 5.25 V
4	+3.3 V	3.135 to 3.465 V
6	+12 V	11.4 to 12.6 V
8	-12 V	-12.6 to -11.4 V
1, 9	Logic Ground	0 V

If the voltages fall within the specified ranges, the chassis complies with the CompactPCI voltage-limit specifications.

Inhibit Mode Switch

On the rear panel of the chassis there is an Inhibit Mode switch. Refer to Figure 1-2, [Rear View of the NI PXIe-1075 Chassis](#), for the location. The Inhibit Mode switch is recessed to prevent it from accidentally being switched.

The Inhibit Mode switch should be in the **Default** position when you want the system controller to control the power supply inhibit. If the user needs to power on a chassis without a system controller installed the switch should be in the **Manual** position.

When the Inhibit Mode switch is set to the **Manual** position, the power supplies are enabled, and you can use the Inhibit signal (active low) on pin 5 of the Remote Inhibit and Voltage Monitoring connector to power off the chassis. To remotely power off the chassis, connect the Inhibit pin (pin 5) to a Logic Ground pin (pin 1 or 9). As long as this connection exists, the chassis will remain off (standby); when you remove this connection, the chassis turns on.



Note For the Remote Inhibit signal to control the On/Off (standby) state of the chassis, the Inhibit Mode switch must be in the **Manual** position.

PXI_CLK10 Rear Connectors

There are two BNC connectors on the rear of the NI PXIe-1075 chassis for PXI_CLK10, as shown in Figure 1-2, *Rear View of the NI PXIe-1075 Chassis*. The connectors are labeled IN and OUT. You can use them for supplying the backplane with PXI_CLK10 or routing the backplane's PXI_CLK10 to another chassis. Refer to the *System Reference Clock* section of Chapter 1, *Getting Started*, for details about these signals.

PXI Express System Configuration with MAX

The PXI Platform Services software included with your chassis automatically identifies your PXI Express system components to generate a `pxiesys.ini` file. You can configure your entire PXI system and identify PXI-1 chassis through Measurement & Automation Explorer (MAX), included with your system controller. MAX creates the `pxiesys.ini` and `pxisys.ini` files, which define your PXI system parameters. MAX also provides an interface to route and reserve triggers so dynamic routing, through drivers such as DAQmx, avoids double-driving and potentially damaging trigger lines. For more information about routing and reserving PXI triggers, refer to KnowledgeBase 3TJDOND8 at ni.com/support.

The configuration steps for single or multiple-chassis systems are the same.

Figure 2-6. Multichassis Configuration in MAX

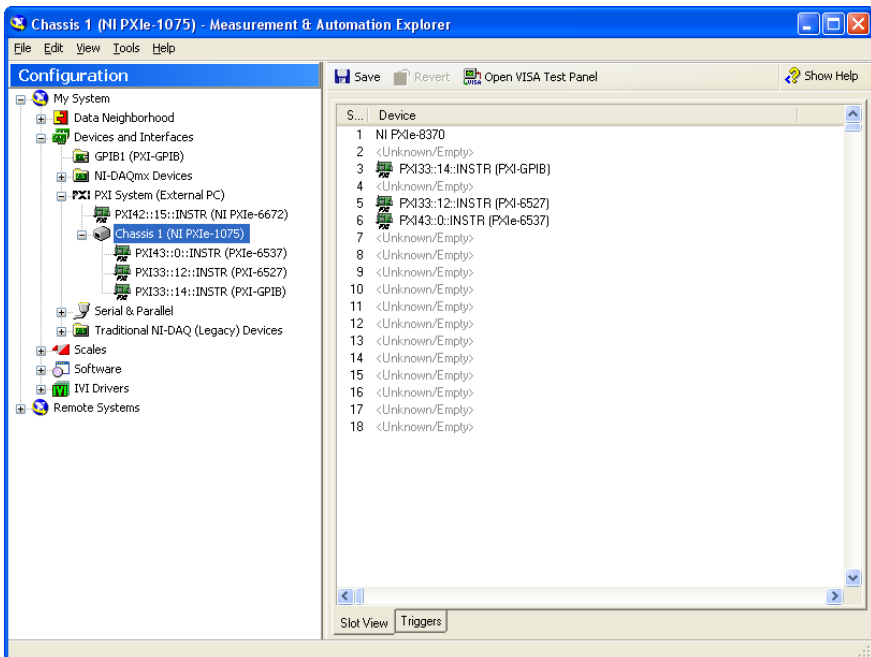

PXI-1 System Configuration

1. Launch MAX.
2. In the **Configuration** tree, click the **Devices and Interfaces** branch to expand it.
3. If the PXI system controller has not yet been configured, it is labeled **PXI System (Unidentified)**. Right-click this entry to display the pop-up menu, then select the appropriate system controller model from the **Identify As** submenu.
4. Click the PXI system controller. The chassis (or multiple chassis, in a multichassis configuration) is listed below it. Identify each chassis by right-clicking its entry, then selecting the appropriate chassis model through the **Identify As** submenu. Further expanding the **PXI System** branch shows all devices in the system that can be recognized by NI-VISA. When your system controller and all your chassis are identified, the required `pxisys.ini` or `pxiesys.ini` file is complete.

The PXI specification allows for many combinations of PXI chassis and system modules. To assist system integrators, the manufacturers of PXI chassis and system modules must document the capabilities of their products. PXI Express devices must provide a driver and `.ini` file for identification. These files are provided as part of the PXI Platform Services software included with your system controller. The minimum documentation requirements for PXI-1 are contained in `.ini` files, which consist of ASCII text. System integrators, configuration utilities, and device drivers can use these `.ini` files.

The capability documentation for a PXI-1 chassis is contained in a `chassis.ini` file provided by the chassis manufacturer. The information in this file is combined with information about the system controller to create a single PXI-1 system initialization file called `pxisys.ini` (PXI System Initialization). The NI system controller uses MAX to generate the `pxisys.ini` file from the `chassis.ini` file.

Device drivers and other utility software read the `pxiesys.ini` and `pxisys.ini` file to obtain system information. For detailed information about initialization files, refer to the PXI specification at www.pxisa.org.

Trigger Configuration in MAX

Each chassis has one or more trigger buses, each with eight lines numbered 0 through 7 that can be reserved and routed statically or dynamically. Static reservation *pre-allocates* a trigger line to prevent its configuration by a user program. Dynamic reservation/routing/deallocation is *on the fly* within a user program based upon National Instruments APIs such as NI-DAQmx. Static reservation of trigger lines can be implemented by the user in MAX through the **Triggers** tab. Reserved trigger lines will not be used by PXI modules dynamically configured by programs such as NI-DAQmx. This prevents the instruments from double-driving the trigger lines, possibly damaging devices in the chassis. In the default configuration, trigger lines on each bus are independent. For example, if trigger line 3 is asserted on trigger bus 0, by default it will not be automatically asserted on any other trigger bus.

Complete the following steps to reserve these trigger lines in MAX.

1. In the Configuration tree, click on the PXI chassis branch you want to configure.
2. Then, in the right-hand pane, toward the bottom, click on the **Triggers** tab.
3. Select which trigger lines you would like to statically reserve.
4. Click the **Apply** button.

PXI Trigger Bus Routing

Some National Instruments chassis, such as the PXI-1075 and the PXI-1044/1045, have the capability to route triggers from one bus to others within the same chassis using the **Trigger Routing** tab in MAX, as shown in Figure 2-6.



Note Selecting any non-disabled routing automatically reserves the line in all trigger buses being routed to. If you are using NI-DAQmx, it will reserve and route trigger lines for you, so you won't have to route trigger lines manually.

Complete the following steps to configure trigger routings in MAX.

1. In the **Configuration** tree, select the chassis in which you want to route trigger lines.
2. In the right-hand pane, select the **Trigger Routing** tab near the bottom.
3. For each trigger line, select **Route Right**, **Route Outward From Middle**, or **Route Left** to route triggers on that line in the described direction, or select **Disabled** for the default behavior with no manual routing.
4. Click the **Apply** button.

Using System Configuration and Initialization Files

The PXI Express specification allows many combinations of PXI Express chassis and system modules. To assist system integrators, the manufacturers of PXI Express chassis and system modules must document the capabilities of their products. The minimum documentation requirements are contained in `.ini` files, which consist of ASCII text. System integrators, configuration utilities, and device drivers can use these `.ini` files.

The capability documentation for the NI PXIe-1075 chassis is contained in the `chassis.ini` file on the software media that comes with the chassis. The information in this file is combined with information about the system controller to create a single system initialization file called `paxisys.ini` (PXI System Initialization). The system controller manufacturer either provides a `paxisys.ini` file for the particular chassis model that contains the system controller or provides a utility that can read an arbitrary `chassis.ini` file and generate the corresponding `paxisys.ini` file. System controllers from NI provide the `paxisys.ini` file for the NI PXIe-1075 chassis, so you should not need to use the `chassis.ini` file. Refer to the documentation provided with the system controller or to ni.com/support for more information on `paxisys.ini` and `chassis.ini` files.

Device drivers and other utility software read the `pxisys.ini` file to obtain system information. The device drivers should have no need to directly read the `chassis.ini` file. For detailed information regarding initialization files, refer to the PXI Express specification at www.pxisa.org.

Maintenance

This chapter describes basic maintenance procedures you can perform on the NI PXIe-1075 chassis.



Caution Disconnect the power cable prior to servicing a NI PXIe-1075 chassis.

Service Interval

Clean the chassis fan filters at a maximum interval of six months. Depending on the amount of use and ambient dust levels in the operating environment, the filters may require more frequent cleaning.

Clean dust from the chassis exterior (and interior) as needed, based on the operating environment. Periodic cleaning increases reliability and cooling performance.

Preparation

The information in this section is designed for use by qualified service personnel. Read the *Read Me First: Safety and Electromagnetic Compatibility* document included with your kit before attempting any procedures in this chapter.



Caution Many components within the chassis are susceptible to static discharge damage. Service the chassis only in a static-free environment. Observe standard handling precautions for static-sensitive devices while servicing the chassis. Always wear a grounded wrist strap or equivalent while servicing the chassis.

Cleaning

Cleaning procedures consist of exterior and interior cleaning of the chassis and cleaning the fan filters. Refer to your module user documentation for information on cleaning the individual CompactPCI or PXI Express modules.



Caution Always disconnect the AC power cable before cleaning or servicing the chassis.

Interior Cleaning

Use a dry, low-velocity stream of air to clean the interior of the chassis. Use a soft-bristle brush for cleaning around components.

Exterior Cleaning

Clean the exterior surfaces of the chassis with a dry lint-free cloth or a soft-bristle brush. If any dirt remains, wipe with a cloth moistened in a mild soap solution. Remove any soap residue by wiping with a cloth moistened with clear water. Do not use abrasive compounds on any part of the chassis.



Caution Avoid getting moisture inside the chassis during exterior cleaning, especially through the top vents. Use just enough moisture to dampen the cloth.

Do *not* wash the front- or rear-panel connectors or switches. Cover these components while cleaning the chassis.

Do *not* use harsh chemical cleaning agents; they may damage the chassis. Avoid chemicals that contain benzene, toluene, xylene, acetone, or similar solvents.

Cleaning the Fan Filters

A dirty fan filter can dramatically affect the cooling performance of an NI PXIe-1075 chassis. Clean the filter whenever it becomes visibly dirty. You can easily remove the chassis air filters from the rear of the chassis by removing the filter retainer. To remove the filter retainer, loosen the retainer screws. The filter cover and retainer are shown in Figure 1-2, [Rear View of the NI PXIe-1075 Chassis](#).

Clean the fan filter by washing it in a mild soap solution and then vacuuming or blowing air through it. Rinse the filter with water and allow it to dry before reinstalling it in the chassis.

You can replace the fan filter with part number RF.09 R-30 from The Filter Factory, Inc., Santa Ynez, CA 93460, if necessary. You also may buy from any other vendor, as long as the filter material is 3/32 in. thick polyurethane foam with a porosity of 30 ppi.

Resetting the AC Mains Circuit Breaker

If the NI PXIe-1075 chassis is connected to an AC source and encounters an over-current condition, the circuit breaker on the rear panel will trip to prevent damage to the chassis. Complete the following steps to reset the circuit breaker.

1. Turn off the chassis.
2. Disconnect the AC power cable.
3. Depress the circuit breaker to reset it.
4. Reconnect the AC power cable.
5. Turn on the chassis.

If the circuit breaker trips again, complete the following steps:

1. Turn off the chassis.
2. Disconnect the AC power cable.
3. Remove all modules from the chassis.
4. Complete the procedure described in the [Connecting to Power Source](#) section of Chapter 2, [Installation and Configuration](#). If the power switch LED is not a steady green, contact National Instruments.
5. Verify that the NI PXIe-1075 chassis can meet the power requirements of your CompactPCI or PXI Express modules. Overloading the chassis can cause the breaker to trip. Refer to Appendix A, [Specifications](#).
6. The over-current condition that caused the circuit breaker to trip may be due to a faulty CompactPCI or PXI Express module. Refer to the documentation supplied with the modules for troubleshooting information.

Replacing the Modular Power Supply Shuttle

This section describes how to remove, configure, and install the AC power supply shuttle in the NI PXIe-1075 chassis. For more information, refer to the *NI PXIe-1075/1065 Power Supply Shuttle User Guide* included with your replacement power supply shuttle module.



Caution Disconnect the power cable prior to replacing the power supply shuttle.

Do not attempt to use a power supply shuttle from another chassis such as the NI PXI-1044/1045. Doing so may damage your chassis and the power supply shuttle.

Before connecting the power supply shuttle to a power source, read this section and the *Read Me First: Safety and Electromagnetic Compatibility* document included with the kit.

Removal

The NI PXIe-1075 AC power supply shuttle is a replacement part for the NI PXIe-1075 AC chassis. Before attempting to replace the power supply shuttle, verify that there is adequate clearance behind the chassis. Disconnect the power cable from the power supply shuttle on the back of the chassis. Identify the ten mounting screws for the NI PXIe-1075 that attach the power supply shuttle to the chassis. Refer to Figure 1-2, [Rear View of the NI PXIe-1075 Chassis](#), for the screw locations. Using a Phillips screwdriver, remove the screws. Pull on the two rear handles of the power supply shuttle to remove it from the back of the chassis.

Installation

Ensure that there is no visible damage to the new power supply shuttle. Verify that the housing and connector on the new power supply shuttle have no foreign material inside. Remove the protective cap on the PXI_CLK10 connector. Install the new power supply shuttle into the opening on the rear of the chassis. Replace and tighten the ten screws with a Phillips screwdriver.

Configuration

The fan-speed selector switch is on the rear panel of the power supply shuttle. Refer to Figure 1-2, *Rear View of the NI PXIe-1075 Chassis*, to locate the fan-speed selector. Select **High** for maximum cooling performance (recommended) or **Auto** for quieter operation. Set the Inhibit Mode switch to the **Default** position.

Connecting Safety Ground

Refer to the *Connecting Safety Ground* section of Chapter 2, *Installation and Configuration*.

Connecting to Power Source

Refer to the *Connecting to Power Source* section of Chapter 2, *Installation and Configuration*.

Specifications

This appendix contains specifications for the NI PXIe-1075 chassis.



Caution Specifications are subject to change without notice.

Electrical

AC Input

Input voltage rating	100 to 120 VAC, 220 to 240 VAC
Operating voltage range ¹	90 to 120 VAC, 200 to 264 VAC
Input current rating	12 A, 6 A
Input frequency	50/60 Hz
Over-current protection	15 A circuit breaker
Line regulation	
3.3 V	<±0.2%
5 V	<±0.1%
±12 V	<±0.1%
Efficiency	70% typical
Power disconnect	The AC power cable provides main power disconnect. The front-panel power switch causes the internal chassis power supply to provide DC power to the CompactPCI/PXI Express backplane. You also can use the rear-panel D-SUB 9-pin connector and power mode switch to control the internal chassis power supply. For

¹ The operating range is guaranteed by design.

more information, refer to the *Inhibit Mode Switch* section of Chapter 2, *Installation and Configuration*.

DC Output

DC current capacity (I_{MP})

Voltage	Maximum Current
+3.3 V	60 A
+5 V	48 A
+12 V	62 A
-12 V	4 A
5 V _{AUX}	2.0 A



Note Maximum total usable power is 791 W.

Backplane slot current capacity

Slot	+5 V	V (I/O)	+3.3 V	+12 V	-12 V	5 V _{AUX}
System Controller Slot	15 A	—	15 A	30 A	—	1 A
System Timing Slot	—	—	6 A	4 A	—	1 A
Hybrid Peripheral Slot with PXI-1 Peripheral	6 A	5 A	6 A	1 A	1 A	—
Hybrid Peripheral Slot with PXI-5 Peripheral	—	—	6 A	4 A	—	1 A



Note Total system slot current should not exceed 45 A.

PCI V(I/O) pins in hybrid slots are connected to +5 V.

The maximum power dissipated in the system slot should not exceed 140 W.

The maximum power dissipated in a peripheral slot should not exceed 38.25 W.

Load regulation

Voltage	Load Regulation
+3.3 V	<5%
+12 V	<5%
+5 V	<5%
-12 V	<5%

Maximum ripple and noise (20 MHz bandwidth)

Voltage	Maximum Ripple and Noise
+3.3 V	50 mV _{pp}
+12 V	50 mV _{pp}
+5 V	50 mV _{pp}
-12 V	50 mV _{pp}

Over-current protection

All outputs protected from short circuit and overload with automatic recovery

Over-voltage protection

3.3 V and 5 V

Clamped at 20 to 30% above nominal output voltage

Power supply shuttle MTTR

Replacement in under 5 minutes

Chassis Cooling

Module cooling system

Forced air circulation (positive pressurization) through three 165 cfm fans with High/Auto speed selector

Slot airflow direction

Bottom of module to top of module

Module cooling intake

Bottom rear of chassis

Module cooling exhaust

Along both sides and top of chassis

Power supply cooling system

Forced air circulation through two integrated fans

Power supply cooling intake

Right side of chassis

Power supply cooling exhaust	Left side of chassis
Clearance for intake/exhaust vents	1.75 in. (44.45 mm) for top and side vents 3.00 in. (76.20 mm) for back vents
Maximum fan cleaning interval	6 months
Fan filter material	30 ppi, 3/32 in. (0.24 mm) polyurethane foam. Refer to the <i>Cleaning the Fan Filters</i> section of Chapter 3, <i>Maintenance</i> , for more information.

Environmental

Maximum altitude	2,000 m (800 mbar) (at 25 °C ambient)
Pollution Degree	2
For indoor use only.	

Operating Environment

Ambient temperature range	0 to 55 °C (Tested in accordance with IEC 60068-2-1 and IEC 60068-2-2. Meets MIL-PRF-28800F Class 3 low temperature limit and MIL-PRF-28800F Class 2 high temperature limit.)
Relative humidity range	10 to 90%, noncondensing (Tested in accordance with IEC 60068-2-56.)

Storage Environment

Ambient temperature range	-40 to 71 °C (Tested in accordance with IEC 60068-2-1 and IEC 60068-2-2. Meets MIL-PRF-28800F Class 3 limits.)
Relative humidity range	5 to 95%, noncondensing (Tested in accordance with IEC 60068-2-56.)

Shock and Vibration

Operational shock	30 g peak, half-sine, 11 ms pulse (Tested in accordance with IEC 60068-2-27. Meets MIL-PRF-28800F Class 2 limits.)
Random Vibration	5 to 500 Hz, 0.3 g _{rms}

Acoustic Emissions

Sound Pressure Level (at Operator Position)

(Tested in accordance with ISO 7779. Meets MIL-PRF-28800F requirements.)

Auto fan (up to ~30 °C ambient)	45.0 dBA
High fan	63.3 dBA

Sound Power

Auto fan (up to ~30 °C ambient)	55.5 dBA
High fan	76.2 dBA



Note For EMC compliance, operate this device with shielded cabling. In addition, all covers and filler panels must be installed. Refer to the Declaration of Conformity (DoC) for this product for any additional regulatory compliance information. To obtain the DoC for this product, visit ni.com/certification, search by model number or product line, and click the appropriate link in the Certification column.

Specifications are subject to change without notice.

Safety

This product is designed to meet the requirements of the following standards of safety for information technology equipment:

- IEC 61010-1, EN 61010-1
- UL 61010-1, CSA 61010-1



Note For UL and other safety certifications, refer to the product label or the [Online Product Certification](#) section.

Electromagnetic Compatibility

This product meets the requirements of the following EMC standards for electrical equipment for measurement, control, and laboratory use:

- EN 61326 (IEC 61326): Class A emissions; Basic immunity
- EN 55011 (CISPR 11): Group 1, Class A emissions
- AS/NZS CISPR 11: Group 1, Class A emissions
- FCC 47 CFR Part 15B: Class A emissions
- ICES-001: Class A emissions



Note For the standards applied to assess the EMC of this product, refer to the [Online Product Certification](#) section.



Note For EMC compliance, operate this device according to printed documentation.

CE Compliance

This product meets the essential requirements of applicable European Directives as follows:

- 2006/95/EC; Low-Voltage Directive (safety)
- 2004/108/EC; Electromagnetic Compatibility Directive (EMC)

Online Product Certification

Refer to the product Declaration of Conformity (DoC) for additional regulatory compliance information. To obtain product certifications and the DoC for this product, visit ni.com/certification, search by model number or product line, and click the appropriate link in the Certification column.

Environmental Management

National Instruments is committed to designing and manufacturing products in an environmentally responsible manner. NI recognizes that eliminating certain hazardous substances from our products is beneficial not only to the environment but also to NI customers.

For additional environmental information, refer to the *NI and the Environment* Web page at ni.com/environment. This page contains the environmental regulations and directives with which NI complies, as well as other environmental information not included in this document.

Waste Electrical and Electronic Equipment (WEEE)



EU Customers At the end of the product life cycle, all products *must* be sent to a WEEE recycling center. For more information about WEEE recycling centers, National Instruments WEEE initiatives, and compliance with WEEE Directive 2002/96/EC on Waste and Electronic Equipment, visit ni.com/environment/weee.

电子信息产品污染控制管理办法（中国 RoHS）



中国客户 National Instruments 符合中国电子信息产品中限制使用某些有害物质指令 (RoHS)。关于 National Instruments 中国 RoHS 合规性信息，请登录 ni.com/environment/rohs_china。(For information about China RoHS compliance, go to ni.com/environment/rohs_china.)

Backplane

Size	3U-sized; one system slot (with three system expansion slots) and 17 peripheral slots. Compliant with IEEE 1101.10 mechanical packaging. PXI Express Specification compliant. Accepts both PXI Express and CompactPCI (PICMG 2.0 R 3.0) 3U modules.
Backplane bare-board material	UL 94 V-0 Recognized
Backplane connectors	Conforms to IEC 917 and IEC 1076-4-101, and are UL 94 V-0 rated

System Synchronization Clocks (PXI_CLK10, PXIe_CLK100, PXIe_SYNC100)

10 MHz System Reference Clock: PXI_CLK10

Maximum slot-to-slot skew	500 ps
Accuracy	±25 ppm max. (guaranteed over the operating temperature range)



Note The 10 MHz system reference clock does not require calibration.

Maximum jitter	5 ps RMS phase-jitter (10 Hz-1 MHz range)
Duty-factor	45 to 55%
Unloaded signal swing	3.3 V ±0.3 V



Note For other specifications refer to the *PXI-1 Hardware Specification*.

100 MHz System Reference Clock: PXIe_CLK100 and PXIe_SYNC100

Maximum slot-to-slot skew	100 ps
Accuracy	±25 ppm max. (guaranteed over the operating temperature range)
Maximum jitter	3 ps RMS phase-jitter (10 Hz to 12 kHz range) 2 ps RMS phase-jitter (12 kHz to 20 MHz range)
Duty-factor for PXIe_CLK100	45 to 55%
Absolute single-ended voltage swing (When each line in the differential pair has 50 Ω termination to 1.30 V or Thévenin equivalent)	400 to 1000 mV



Note For other specifications refer to the *PXI-5 PXI Express Hardware Specification*.

External 10 MHz Reference Out (BNC on rear panel of chassis)

Accuracy	±25 ppm max. (guaranteed over the operating temperature range)
Maximum jitter	5 ps RMS phase-jitter (10 Hz to 1 MHz range)
Output amplitude	1 V _{pp} ±20% square-wave into 50 Ω 2 V _{pp} unloaded
Output impedance	50 Ω ±5 Ω

External Clock Source

Frequency	10 MHz ±100 PPM
Input amplitude	
Rear panel BNC	200 mV _{pp} to 5 V _{pp} square-wave or sine-wave
System timing slot PXI_CLK10_IN	5 V or 3.3 V TTL signal

Rear panel BNC input impedance	50 Ω \pm 5 Ω
Maximum jitter introduced by backplane	1 ps RMS phase-jitter (10 Hz to 1 MHz range)

PXIe_SYNC_CTRL

V _{IH}	2.0 to 5.5 V
V _{IL}	0 to 0.8 V

PXI Star Trigger

Maximum slot-to-slot skew	250 ps
Backplane characteristic impedance	65 Ω \pm 10%



Note For PXI slot to PXI Star mapping refer to the [System Timing Slot](#) section of Chapter 1, [Getting Started](#).

For other specifications refer to the *PXI-1 Hardware Specification*.

PXI Differential Star Triggers (PXIe-DSTARA, PXIe-DSTARB, PXIe-DSTARC)

Maximum slot-to-slot skew	150 ps
Maximum differential skew	25 ps
Backplane differential impedance	100 Ω \pm 10%



Note For PXIe slot to PXI_DSTAR mapping refer to the [System Timing Slot](#) section of Chapter 1, [Getting Started](#).

For other specifications, the NI PXIe-1075 complies with the *PXI-5 PXI Express Hardware Specification*.

Mechanical

Overall dimensions

Standard chassis

Height	6.97 in. (177.1 mm)
Width	18.30 in. (464.8 mm)
Depth	18.40 in. (467.4 mm)



Note 0.57 in. (14.5 mm) is added to height when feet are installed. When tilted with front feet extended on table top, height is increased approximately 2.08 in. (52.8 mm) in front and 0.583 in. (14.8 mm) in rear.

Weight	31.0 lb (14.06 kg)
Chassis materials	Sheet Aluminum (5052-H32, 3003-H14, and 6061-T6), Extruded Aluminum (6060-T6), and Cold Rolled Steel, PC-ABS, Santoprene, Nylon
Finish	Conductive Clear Iridite on Aluminum Electroplated Nickel on Cold Rolled Steel Polyurethane Enamel

Figures A-1 and A-2 show the NI PXIe-1075 chassis dimensions. The holes shown are for the installation of the optional rack mount kits. You can install those kits on the front or rear of the chassis, depending on which end of the chassis you want to face toward the front of the instrument cabinet. Notice that the front and rear chassis mounting holes (size M4) are symmetrical.

Figure A-1. NI PXIe-1075 Chassis Dimensions (Front and Side)

Dimensions are in inches (millimeters)

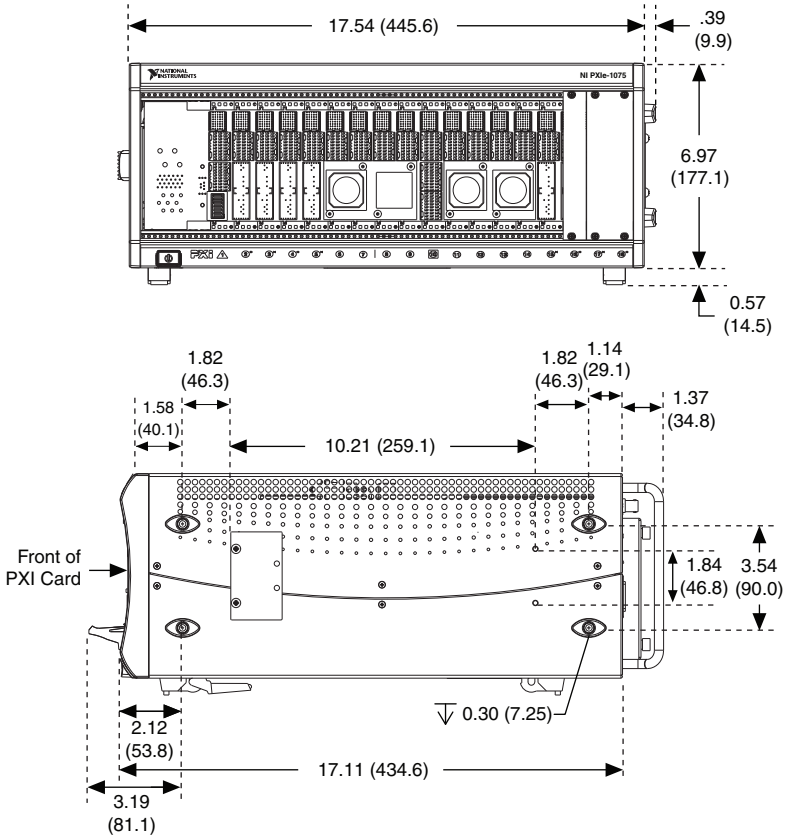

Figure A-2. NI PXIe-1075 Chassis Dimensions (Bottom)

Dimensions are in inches (millimeters)

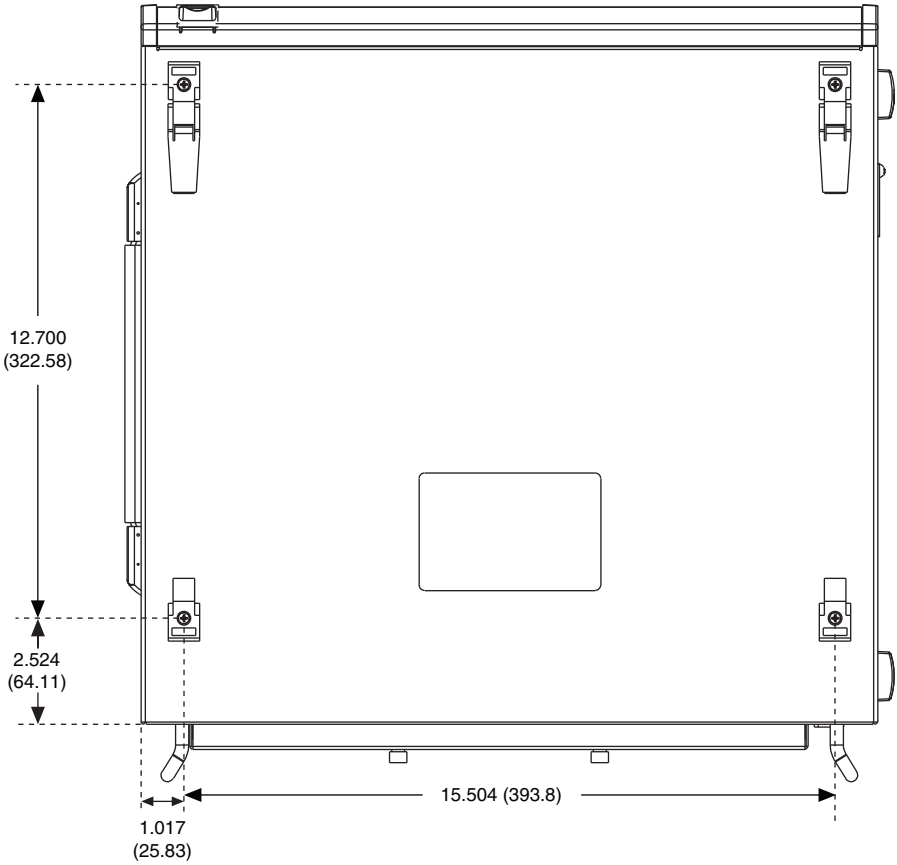
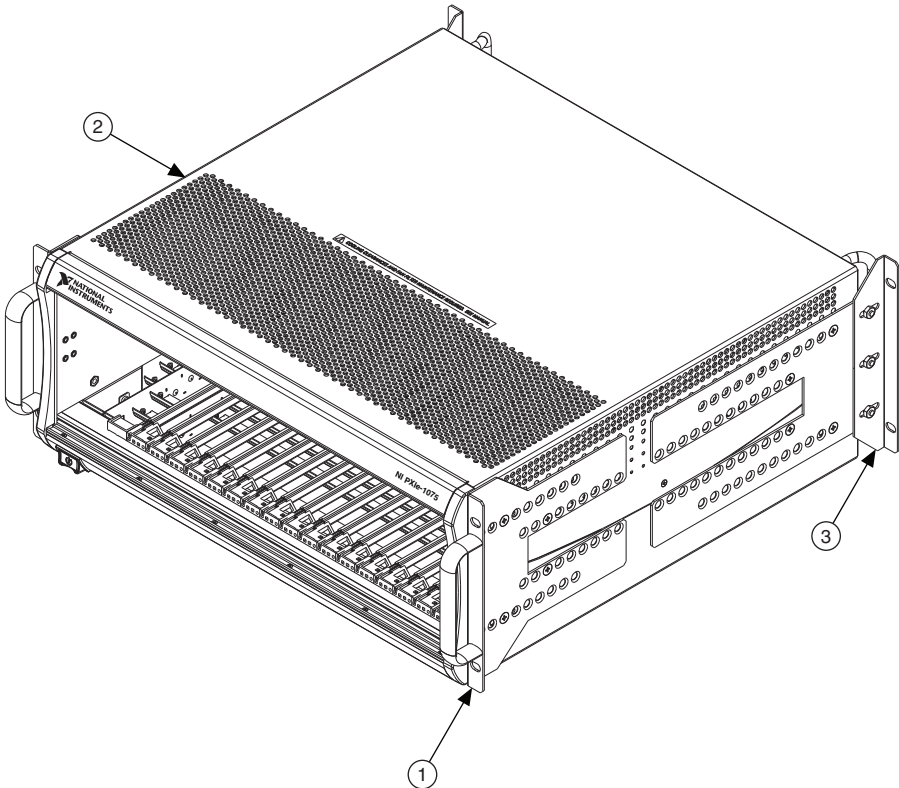

Figure A-3 shows the chassis rack mount kit components.

Figure A-3. NI Chassis Rack Mount Kit Components



1 Front Rack Mount Kit

2 NI Chassis

3 Optional Rear Rack Mount Kit



Note The chassis shown in Figure A-3 is representative of the NI PXI-1044/1045 and NI PXIe-1075 product line.

For more information on rack mounting the NI PXIe-1075 chassis, refer to the printed installation guide included with your rack mount kit.

Pinouts

This appendix describes the connector pinouts for the NI PXIe-1075 chassis backplane.

Figure B-1 illustrates the types of PXIe connectors by providing a layout of the PXI Express system controller slot (slot 1).

Table B-1 shows the XP4 Connector Pinout for the System Controller slot.

Table B-2 shows the XP3 Connector Pinout for the System Controller slot.

Table B-3 shows the XP2 Connector Pinout for the System Controller slot.

Table B-4 shows the XP1 connector pinout for the System Controller slot.

Table B-5 shows the XP4 Connector Pinout for the System Timing slot.

Table B-6 shows the XP3 Connector Pinout for the System Timing slot.

Table B-7 shows the TP2 Connector Pinout for the System Timing slot.

Table B-8 shows the TP1 Connector Pinout for the System Timing slot.

Table B-9 shows the XP4 Connector Pinout for the Hybrid peripheral slots.

Table B-10 shows the XP3 Connector Pinout for the Hybrid peripheral slots.

Table B-11 shows the P1 connector pinout for the Hybrid peripheral slots.

For more detailed information, refer to the *PXI-5 PXI Express Hardware Specification*, Revision 2.0. Contact the PXI Systems Alliance for a copy of the specification.

System Controller Slot Pinouts

Figure B-1. PXI Express System Controller Slot Layout

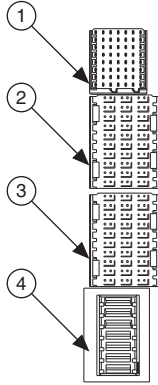

-
- 1 XP4 Connector
 - 2 XP3 Connector

- 3 XP2 Connector
 - 4 XP1 Connector
-

Table B-1. XP4 Connector Pinout for the System Controller Slot

Pin	Z	A	B	C	D	E	F
1	GND	GA4	GA3	GA2	GA1	GA0	GND
2	GND	5Vaux	GND	SYSEN#	WAKE#	ALERT#	GND
3	GND	RSV	RSV	RSV	RSV	RSV	GND
4	GND	RSV	RSV	RSV	RSV	RSV	GND
5	GND	PXI_TRIG3	PXI_TRIG4	PXI_TRIG5	GND	PXI_TRIG6	GND
6	GND	PXI_TRIG2	GND	RSV	PXI_STAR	PXI_CLK10	GND
7	GND	PXI_TRIG1	PXI_TRIG0	RSV	GND	PXI_TRIG7	GND
8	GND	RSV	GND	RSV	RSV	PXI_LBR6	GND

Table B-2. XP3 Connector Pinout for the System Controller Slot

Pin	A	B	ab	C	D	cd	E	F	ef
1	RSV	RSV	GND	RSV	RSV	GND	RSV	RSV	GND
2	RSV	RSV	GND	PWR_OK	PS_ON#	GND	LINKCAP	PWRBTN#	GND
3	SMBDAT	SMBCLK	GND	4RefClk+	4RefClk-	GND	2RefClk+	2RefClk-	GND
4	RSV	PERST#	GND	3RefClk+	3RefClk-	GND	1RefClk+	1RefClk-	GND
5	1PETp0	1PETn0	GND	1PERp0	1PERn0	GND	1PETp1	1PETn1	GND
6	1PETp2	1PETn2	GND	1PERp2	1PERn2	GND	1PERp1	1PERn1	GND

Table B-2. XP3 Connector Pinout for the System Controller Slot (Continued)

Pin	A	B	ab	C	D	cd	E	F	ef
7	1PETp3	1PETn3	GND	1PERp3	1PERn3	GND	2PETp0	2PETn0	GND
8	2PETp1	2PETn1	GND	2PERp1	2PERn1	GND	2PERp0	2PERn0	GND
9	2PETp2	2PETn2	GND	2PERp2	2PERn2	GND	2PETp3	2PETn3	GND
10	3PETp0	3PETn0	GND	3PERp0	3PERn0	GND	2PERp3	2PERn3	GND

Table B-3. XP2 Connector Pinout for the System Controller Slot

Pin	A	B	ab	C	D	cd	E	F	ef
1	3PETp1	3PETn1	GND	3PERp1	3PERn1	GND	3PETp2	3PETn2	GND
2	3PETp3	3PETn3	GND	3PERp3	3PERn3	GND	3PERp2	3PERn2	GND
3	4PETp0	4PETn0	GND	4PERp0	4PERn0	GND	4PETp1	4PETn1	GND
4	4PETp2	4PETn2	GND	4PERp2	4PERn2	GND	4PERp1	4PERn1	GND
5	4PETp3	4PETn3	GND	4PERp3	4PERn3	GND	RSV	RSV	GND
6	RSV	RSV	GND	RSV	RSV	GND	RSV	RSV	GND
7	RSV	RSV	GND	RSV	RSV	GND	RSV	RSV	GND
8	RSV	RSV	GND	RSV	RSV	GND	RSV	RSV	GND
9	RSV	RSV	GND	RSV	RSV	GND	RSV	RSV	GND
10	RSV	RSV	GND	RSV	RSV	GND	RSV	RSV	GND

Table B-4. XP1 Connector Pinout for the System Controller Slot

Pins	Signals
A	GND
B	12V
C	12V
D	GND
E	5V
F	3.3V
G	GND

System Timing Slot Pinouts

Figure B-2. PXI Express System Timing Slot Layout

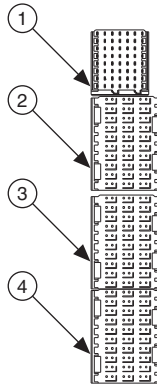

- 1 XP4 Connector
- 2 XP3 Connector

- 3 TP2 Connector
- 4 TP1 Connector

Table B-5. XP4 Connector Pinout for the System Timing Slot

Pin	Z	A	B	C	D	E	F
1	GND	GA4	GA3	GA2	GA1	GA0	GND
2	GND	5V _{aux}	GND	SYSEN#	WAKE#	ALERT#	GND
3	GND	12V	12V	GND	GND	GND	GND
4	GND	GND	GND	3.3V	3.3V	3.3V	GND
5	GND	PXI_TRIG3	PXI_TRIG4	PXI_TRIG5	GND	PXI_TRIG6	GND
6	GND	PXI_TRIG2	GND	ATNLED	PXI_CLK10_IN	PXI_CLK10	GND
7	GND	PXI_TRIG1	PXI_TRIG0	ATNSW#	GND	PXI_TRIG7	GND
8	GND	PXIe_SYNC_CTRL	GND	RSV	PXI_LBL6	PXI_LBR6	GND

Table B-6. XP3 Connector Pinout for the System Timing Slot

Pin	A	B	ab	C	D	cd	E	F	ef
1	PXIe_CLK100+	PXIe_CLK100-	GND	PXIe_SYNC100+	PXIe_SYNC100-	GND	PXIe_DSTARC+	PXIe_DSTARC-	GND
2	PRSNT#	PWREN#	GND	PXIe_DSTARB+	PXIe_DSTARB-	GND	PXIe_DSTARA+	PXIe_DSTARA-	GND
3	SMBDAT	SMBCLK	GND	RSV	RSV	GND	RSV	RSV	GND
4	MPWRGD*	PERST#	GND	RSV	RSV	GND	1RefClk+	1RefClk-	GND
5	1PETp0	1PETn0	GND	1PERp0	1PERn0	GND	1PETp1	1PETn1	GND

Table B-6. XP3 Connector Pinout for the System Timing Slot (Continued)

Pin	A	B	ab	C	D	cd	E	F	ef
6	1PETp2	1PETn2	GND	1PERp2	1PERn2	GND	1PERp1	1PERn1	GND
7	1PETp3	1PETn3	GND	1PERp3	1PERn3	GND	1PETp4	1PETn4	GND
8	1PETp5	1PETn5	GND	1PERp5	1PERn5	GND	1PERp4	1PERn4	GND
9	1PETp6	1PETn6	GND	1PERp6	1PERn6	GND	1PETp7	1PETn7	GND
10	RSV	RSV	GND	RSV	RSV	GND	1PERp7	1PERn7	GND

Table B-7. TP2 Connector Pinout for the System Timing Slot

Pin	A	B	ab	C	D	cd	E	F	ef
1	PXIe_ DSTARC0+	PXIe_ DSTARC0-	GND	PXIe_ DSTARC8+	PXIe_ DSTARC8-	GND	PXIe_ DSTARB8+	PXIe_ DSTARB8-	GND
2	PXIe_ DSTARA0+	PXIe_ DSTARA0-	GND	PXIe_ DSTARC9+	PXIe_ DSTARC9-	GND	PXIe_ DSTARA8+	PXIe_ DSTARA8-	GND
3	PXIe_ DSTARB0+	PXIe_ DSTARB0-	GND	PXIe_ DSTARC1+	PXIe_ DSTARC1-	GND	PXIe_ DSTARA9+	PXIe_ DSTARA9-	GND
4	PXIe_ DSTARB1+	PXIe_ DSTARB1-	GND	PXI_STAR0	PXI_STAR1	GND	PXIe_ DSTARB9+	PXIe_ DSTARB9-	GND
5	PXIe_ DSTARA1+	PXIe_ DSTARA1-	GND	PXI_STAR2	PXI_STAR3	GND	PXIe_ DSTARC10+	PXIe_ DSTARC10-	GND
6	PXIe_ DSTARC2+	PXIe_ DSTARC2-	GND	PXI_STAR4	PXI_STAR5	GND	PXIe_ DSTARA10+	PXIe_ DSTARA10-	GND

Table B-7. TP2 Connector Pinout for the System Timing Slot (Continued)

Pin	A	B	ab	C	D	cd	E	F	ef
7	PXIe_ DSTARB2+	PXIe_ DSTARB2-	GND	PXI_STAR6	PXI_STAR7	GND	PXIe_ DSTARB10+	PXIe_ DSTARB10-	GND
8	PXIe_ DSTARA2+	PXIe_ DSTARA2-	GND	PXI_STAR8	PXI_STAR9	GND	PXIe_ DSTARC11+	PXIe_ DSTARC11-	GND
9	PXIe_ DSTARC3+	PXIe_ DSTARC3-	GND	PXI_ STAR10	PXI_ STAR11	GND	PXIe_ DSTARA11+	PXIe_ DSTARA11-	GND
10	PXIe_ DSTARB3+	PXIe_ DSTARB3-	GND	PXIe_ DSTARC16+	PXIe_ DSTARC16-	GND	PXIe_ DSTARB11+	PXIe_ DSTARB11-	GND

Table B-8. TP1 Connector Pinout for the System Timing Slot

Pin	A	B	ab	C	D	cd	E	F	ef
1	PXIe_ DSTARA3+	PXIe_ DSTARA3-	GND	PXIe_ DSTARC7+	PXIe_ DSTARC7-	GND	PXIe_ DSTARC12+	PXIe_ DSTARC12-	GND
2	PXIe_ DSTARC4+	PXIe_ DSTARC4-	GND	PXI_STAR12	PXI_ STAR13	GND	PXIe_ DSTARA12+	PXIe_ DSTARA12-	GND
3	PXIe_ DSTARB4+	PXIe_ DSTARB4-	GND	PXIe_ DSTARA16+	PXIe_ DSTARA16-	GND	PXIe_ DSTARB12+	PXIe_ DSTARB12-	GND
4	PXIe_ DSTARA4+	PXIe_ DSTARA4-	GND	PXIe_ DSTARB7+	PXIe_ DSTARB7-	GND	PXIe_ DSTARC13+	PXIe_ DSTARC13-	GND
5	PXIe_ DSTARC5+	PXIe_ DSTARC5-	GND	PXI_STAR14	PXI_ STAR15	GND	PXIe_ DSTARA13+	PXIe_ DSTARA13-	GND

Table B-8. TP1 Connector Pinout for the System Timing Slot (Continued)

Pin	A	B	ab	C	D	cd	E	F	ef
6	PXle_ DSTARB5+	PXle_ DSTARB5-	GND	PXle_ DSTARB16+	PXle_ DSTARB16-	GND	PXle_ DSTARB13+	PXle_ DSTARB13-	GND
7	PXle_ DSTARA5+	PXle_ DSTARA5-	GND	PXle_ DSTARA7+	PXle_ DSTARA7-	GND	PXle_ DSTARC14+	PXle_ DSTARC14-	GND
8	PXle_ DSTARC6+	PXle_ DSTARC6-	GND	PXI_STAR16	RSV	GND	PXle_ DSTARA14+	PXle_ DSTARA14-	GND
9	PXle_ DSTARB6+	PXle_ DSTARB6-	GND	PXle_ DSTARC15+	PXle_ DSTARC15-	GND	PXle_ DSTARB14+	PXle_ DSTARB14-	GND
10	PXle_ DSTARA6+	PXle_ DSTARA6-	GND	PXle_ DSTARB15+	PXle_ DSTARB15-	GND	PXle_ DSTARA15+	PXle_ DSTARA15-	GND

Hybrid Slot Pinouts

Figure B-3. PXI Express System Hybrid Slot Layout

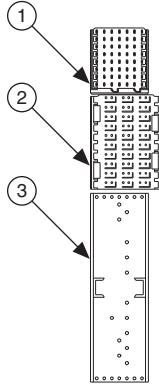

1 XP4 Connector

2 XP3 Connector

3 P1 Connector

Table B-9. XP4 Connector Pinout for the Hybrid Slot

Pin	Z	A	B	C	D	E	F
1	GND	GA4	GA3	GA2	GA1	GA0	GND
2	GND	5Vaux	GND	SYSEN#	WAKE#	ALERT#	GND
3	GND	12V	12V	GND	GND	GND	GND
4	GND	GND	GND	3.3V	3.3V	3.3V	GND
5	GND	PXI_TRIG3	PXI_TRIG4	PXI_TRIG5	GND	PXI_TRIG6	GND
6	GND	PXI_TRIG2	GND	ATNLED	PXI_STAR	PXI_CLK10	GND
7	GND	PXI_TRIG1	PXI_TRIG0	ATNSW#	GND	PXI_TRIG7	GND
8	GND	RSV	GND	RSV	PXI_LBL6	PXI_LBR6	GND

Table B-10. XP3 Connector Pinout for the Hybrid Slot

Pin	A	B	ab	C	D	cd	E	F	ef
1	PXIe_ CLK100+	PXIe_ CLK100-	GND	PXIe_ SYNC100+	PXIe_ SYNC100-	GND	PXIe_ DSTARC+	PXIe_ DSTARC-	GND
2	PRSNT#	PWREN#	GND	PXIe_ DSTARB+	PXIe_ DSTARB-	GND	PXIe_ DSTARA+	PXIe_ DSTARA-	GND
3	SMBDAT	SMBCLK	GND	RSV	RSV	GND	RSV	RSV	GND
4	MPWRGD*	PERST#	GND	RSV	RSV	GND	1RefClk+	1RefClk-	GND
5	1PETp0	1PETn0	GND	1PERp0	1PERn0	GND	1PETp1	1PETn1	GND

Table B-10. XP3 Connector Pinout for the Hybrid Slot (Continued)

Pin	A	B	ab	C	D	cd	E	F	ef
6	1PETp2	1PETn2	GND	1PERp2	1PERn2	GND	1PERp1	1PERn1	GND
7	1PETp3	1PETn3	GND	1PERp3	1PERn3	GND	1PETp4	1PETn4	GND
8	1PETp5	1PETn5	GND	1PERp5	1PERn5	GND	1PERp4	1PERn4	GND
9	1PETp6	1PETn6	GND	1PERp6	1PERn6	GND	1PETp7	1PETn7	GND
10	RSV	RSV	GND	RSV	RSV	GND	1PERp7	1PERn7	GND

Table B-11. P1 Connector Pinout for the Hybrid Slot

Pin	Z	A	B	C	D	E	F
25	GND	5V	REQ64#	ENUM#	3.3V	5V	GND
24	GND	AD[1]	5V	V(I/O)	AD[0]	ACK64#	GND
23	GND	3.3V	AD[4]	AD[3]	5V	AD[2]	GND
22	GND	AD[7]	GND	3.3V	AD[6]	AD[5]	GND
21	GND	3.3V	AD[9]	AD[8]	M66EN	C/BE[0]#	GND
20	GND	AD[12]	GND	V(I/O)	AD[11]	AD[10]	GND
19	GND	3.3V	AD[15]	AD[14]	GND	AD[13]	GND
18	GND	SERR#	GND	3.3V	PAR	C/BE[1]#	GND
17	GND	3.3V	IPMB_SCL	IPMB_SDA	GND	PERR#	GND

Table B-11. P1 Connector Pinout for the Hybrid Slot (Continued)

Pin	Z	A	B	C	D	E	F
16	GND	DEVSEL#	GND	V(I/O)	STOP#	LOCK#	GND
15	GND	3.3V	FRAME#	IRDY#	BD_SEL#	TRDY#	GND
12 to 14	Key Area						
11	GND	AD[18]	AD[17]	AD[16]	GND	C/BE[2]#	GND
10	GND	AD[21]	GND	3.3V	AD[20]	AD[19]	GND
9	GND	C/BE[3]#	IDSEL	AD[23]	GND	AD[22]	GND
8	GND	AD[26]	GND	V(I/O)	AD[25]	AD[24]	GND
7	GND	AD[30]	AD[29]	AD[28]	GND	AD[27]	GND
6	GND	REQ#	GND	3.3V	CLK	AD[31]	GND
5	GND	BRSVP1A5	BRSVP1B5	RST#	GND	GNT#	GND
4	GND	IPMB_PWR	HEALTHY#	V(I/O)	INTP	INTS	GND
3	GND	INTA#	INTB#	INTC#	5V	INTD#	GND
2	GND	TCK	5V	TMS	TDO	TDI	GND
1	GND	5V	-12V	TRST#	+12V	5V	GND



NI Services

NI provides global services and support as part of our commitment to your success. Take advantage of product services in addition to training and certification programs that meet your needs during each phase of the application life cycle; from planning and development through deployment and ongoing maintenance.

To get started, register your product at ni.com/myproducts.

As a registered NI product user, you are entitled to the following benefits:

- Access to applicable product services.
- Easier product management with an online account.
- Receive critical part notifications, software updates, and service expirations.

Log in to your MyNI user profile to get personalized access to your services.

Services and Resources

- **Maintenance and Hardware Services**—NI helps you identify your systems' accuracy and reliability requirements and provides warranty, sparing, and calibration services to help you maintain accuracy and minimize downtime over the life of your system. Visit ni.com/services for more information.
 - **Warranty and Repair**—All NI hardware features a one-year standard warranty that is extendable up to five years. NI offers repair services performed in a timely manner by highly trained factory technicians using only original parts at an NI service center.
 - **Calibration**—Through regular calibration, you can quantify and improve the measurement performance of an instrument. NI provides state-of-the-art calibration services. If your product supports calibration, you can obtain the calibration certificate for your product at ni.com/calibration.
- **System Integration**—If you have time constraints, limited in-house technical resources, or other project challenges, National Instruments Alliance Partner members can help. To learn more, call your local NI office or visit ni.com/alliance.

- **Training and Certification**—The NI training and certification program is the most effective way to increase application development proficiency and productivity. Visit ni.com/training for more information.
 - The Skills Guide assists you in identifying the proficiency requirements of your current application and gives you options for obtaining those skills consistent with your time and budget constraints and personal learning preferences. Visit ni.com/skills-guide to see these custom paths.
 - NI offers courses in several languages and formats including instructor-led classes at facilities worldwide, courses on-site at your facility, and online courses to serve your individual needs.
- **Technical Support**—Support at ni.com/support includes the following resources:
 - **Self-Help Technical Resources**—Visit ni.com/support for software drivers and updates, a searchable KnowledgeBase, product manuals, step-by-step troubleshooting wizards, thousands of example programs, tutorials, application notes, instrument drivers, and so on. Registered users also receive access to the NI Discussion Forums at ni.com/forums. NI Applications Engineers make sure every question submitted online receives an answer.
 - **Software Support Service Membership**—The Standard Service Program (SSP) is a renewable one-year subscription included with almost every NI software product, including NI Developer Suite. This program entitles members to direct access to NI Applications Engineers through phone and email for one-to-one technical support, as well as exclusive access to online training modules at ni.com/self-paced-training. NI also offers flexible extended contract options that guarantee your SSP benefits are available without interruption for as long as you need them. Visit ni.com/ssp for more information.
- **Declaration of Conformity (DoC)**—A DoC is our claim of compliance with the Council of the European Communities using the manufacturer’s declaration of conformity. This system affords the user protection for electromagnetic compatibility (EMC) and product safety. You can obtain the DoC for your product by visiting ni.com/certification.

For information about other technical support options in your area, visit ni.com/services, or contact your local office at ni.com/contact.

You also can visit the Worldwide Offices section of ni.com/niglobal to access the branch office websites, which provide up-to-date contact information, support phone numbers, email addresses, and current events.

Glossary

Symbol	Prefix	Value
p	pico	10^{-12}
n	nano	10^{-9}
μ	micro	10^{-6}
m	milli	10^{-3}
k	kilo	10^3
M	mega	10^6
G	giga	10^9
T	tera	10^{12}

Symbols

°	Degrees.
≥	Equal or greater than.
≤	Equal or less than.
%	Percent.

A

A	Amperes.
AC	Alternating current.
ANSI	American National Standards Institute.
Auto	Automatic fan speed control.
AWG	American Wire Gauge.

B

backplane An assembly, typically a printed circuit board, with connectors and signal paths that bus the connector pins.

BNC Bayonet Neill Concelman connector; a commonly used coaxial connector.

C

C Celsius.

cfm Cubic feet per minute.

CFR Code of Federal Regulations.

cm Centimeters.

CompactPCI An adaptation of the Peripheral Component Interconnect (PCI) Specification 2.1 or later for industrial and/or embedded applications requiring a more robust mechanical form factor than desktop PCI. It uses industry standard mechanical components and high-performance connector technologies to provide an optimized system intended for rugged applications. It is electrically compatible with the PCI Specification, which enables low-cost PCI components to be utilized in a mechanical form factor suited for rugged environments.

CSA Canadian Standards Association.

D

daisy-chain A method of propagating signals along a bus, in which the devices are prioritized on the basis of their position on the bus.

DB-9 A 9-pin D-SUB connector.

DC Direct current.

DoC Declaration of Conformity.

D-SUB Subminiature D connector.

E

efficiency	Ratio of output power to input power, expressed as a percentage.
EIA	Electronic Industries Association.
EMC	Electromagnetic Compatibility.
EMI	Electromagnetic Interference.

F

FCC	Federal Communications Commission.
filler panel	A blank module front panel used to fill empty slots in the chassis.

G

g	(1) grams; (2) a measure of acceleration equal to 9.8 m/s^2 .
GPIB	General Purpose Interface Bus (IEEE 488).
g_{RMS}	A measure of random vibration. The root mean square of acceleration levels in a random vibration test profile.

H

hr	Hours.
Hz	Hertz; cycles per second.

I

IEC	International Electrotechnical Commission; an organization that sets international electrical and electronics standards.
IEEE	Institute of Electrical and Electronics Engineers.
I_{MP}	Mainframe peak current.

Glossary

in. Inches.

inhibit To turn off.

J

jitter A measure of the small, rapid variations in clock transition times from their nominal regular intervals. Units: seconds RMS.

K

kg Kilograms.

km Kilometers.

L

lb Pounds.

LED Light emitting diode.

line regulation The maximum steady-state percentage that a DC voltage output will change as a result of a specified change in input AC voltage (step change from 90 VAC to 132 VAC or 180 VAC to 264 VAC).

load regulation The maximum steady-state percentage that a DC voltage output will change as a result of a step change from no-load to full-load output current.

M

m Meters.

MHz Megahertz. One million Hertz; one Hertz equals one cycle per second.

mi Miles.

ms Milliseconds.

MTBF Mean time between failure.

MTTR Mean time to repair.

N

NEMA	National Electrical Manufacturers Association.
NI	National Instruments.

P

power supply shuttle	A removable module that contains the chassis power supply.
PXI	PCI eXtensions for Instrumentation.
PXI_CLK10	10 MHz PXI system reference clock.

R

RH	Relative humidity.
RMS	Root mean square.

S

s	Seconds.
skew	Deviation in signal transmission times.
slot blocker	An assembly installed into an empty slot to improve the airflow in adjacent slots.
standby	The backplane is unpowered (off), but the chassis is still connected to AC power mains.
System controller	A module configured for installation in Slot 1 of a PXI chassis. This device is unique in the PXI system in that it performs the system controller functions, including clock sourcing and arbitration for data transfers across the backplane. Installing such a device into any other slot can damage the device, the PXI backplane, or both.

Glossary

system reference clock A 10 MHz clock, also called PXI_CLK10, that is distributed to all peripheral slots in the chassis, as well as a BNC connector on the rear of chassis labeled *10 MHz REF OUT*. The system reference clock can be used for synchronization of multiple modules in a measurement or control system. The 10 MHz REF IN and OUT BNC connectors on the rear of the chassis can be used to synchronize multiple chassis to one reference clock. The PXI backplane specification defines implementation guidelines for PXI_CLK10.

System Timing slot This slot is located at slot 4 and has dedicated trigger lines to other slots.

T

TTL Transistor-transistor logic.

U

UL Underwriter's Laboratories.

V

V Volts.

VAC Volts alternating current.

V_{pp} Peak-to-peak voltage.

W

W Watts.

Index

A

AC power cables (table), 1-1
AC power cables, part numbers (table), 1-2
architecture, backplane, 1-6

B

backplane
 architecture, 1-6
 hybrid peripheral slots, 1-7
 interoperability with CompactPCI, 1-6
 overview, 1-6
 PXI Express peripheral slots, 1-7
 PXI local bus, routing, 1-9
 PXIe_SYNC_CTRL, 1-12
 specifications, A-7
 system controller slot, 1-6
 system reference clock, 1-10
 default behavior (figure), 1-10
 system timing slot, 1-8
 trigger bus, 1-9

C

cables, power (table), 1-1
cables, power, part numbers (table), 1-2
CE compliance specifications, A-6
chassis ambient temperature definitions, 2-3
chassis cooling considerations
 ambient temperature definitions, 2-3
 clearances, 2-2
 figure, 2-2
 vents (figure), 2-3
chassis initialization file, 2-13
chassis ventilation (figure), 2-3
clearances for chassis cooling, 2-2
 figure, 2-2
CLK10 rear connectors, 2-11
CompactPCI interoperability with NI
 PXIe-1075 backplane, 1-6
configuration in MAX (figure), 2-11
configuration. *See* installation, configuration,
 and operation
connector pinouts. *See* pinouts

cooling

air cooling of PXIe-1075 chassis, 2-2
filler panel installation, 2-4
setting fan speed, 2-4
slot blocker installation, 2-4

D

DB-9 connector
 pinout (table), 2-9
 power supply voltages (table), 2-10
dimensions (figure), A-11, A-12
documentation, related, *vii*

E

electromagnetic compatibility, A-6
EMC filler panel kit, 1-5
external clock source specifications, A-8

F

fan, setting speed, 2-4
filler panel installation, 2-4

G

ground, connecting, 2-4

H

hybrid peripheral slots, description, 1-7
hybrid slot pinouts
 P1 connector (table), B-12
 XP3 connector (table), B-11
 XP4 connector (table), B-11

I

IEC 320 inlet, 1-5, 2-5
inhibit mode switch, 2-10
installation, configuration, and operation
 chassis initialization file, 2-13
 configuration in MAX (figure), 2-11
 connecting safety ground, 2-4
 filler panel installation, 2-4

- installing a PXI Express system controller, 2-5
 - figure, 2-6
- module installation
 - CompactPCI or PXI modules (figure), 2-8
- peripheral module installation, 2-7
 - figure, 2-8
- PXI Express configuration in MAX, 2-11
- PXI Express system controller installed in a NI PXIe-1075 chassis (figure), 2-7
- PXI-1 configuration in MAX, 2-12
- rack mounting, 2-4
- remote voltage monitoring and inhibiting interface, 2-9
- setting fan speed, 2-4
- site considerations, 2-2
- slot blocker installation, 2-4
- testing power up, 2-5
- unpacking the PXIe-1075, 1-1
- installing a PXI Express system controller (figure), 2-6
- interoperability with CompactPCI, 1-6

K

- key features, 1-2
- kit contents, 1-1

L

- local bus, routing (figure), 1-9

M

- maintenance of NI PXIe-1075 chassis, 3-1
 - cleaning
 - exterior cleaning, 3-2
 - interior cleaning, 3-1
 - preparation, 3-1
 - resetting the AC mains circuit
 - breaker, 3-2
 - service interval, 3-1
 - static discharge damage (caution), 3-1

N

NI PXIe-1075

- architecture, backplane, 1-6
- backplane overview, 1-6
- fan speed, setting, 2-4
- front view (figure), 1-4
- hybrid peripheral slots, 1-7
- installation. *See* installation, configuration, and operation
- interoperability with CompactPCI, 1-6
- key features, 1-2
- maintenance. *See* maintenance of NI PXIe-1075 chassis
- optional equipment, 1-5
- PXI Express peripheral slots, 1-7
- PXI local bus, routing, 1-9
- PXIe_SYNC_CTRL, 1-12
 - using as restart (figure), 1-12
- rack mounting, 2-4
- rear view of NI PXIe-1075 chassis, 1-5
- safety ground, connecting, 2-4
- specifications, A-7
- system controller slot, 1-6
- system reference clock, 1-10
 - default behavior (figure), 1-10
- system timing slot, 1-8
- trigger bus, 1-9
- unpacking, 1-1
- NI PXIe-1075 backplane interoperability with CompactPCI, 1-6

O

- optional equipment, 1-5

P

- peripheral module installation, 2-7
 - figure, 2-8
- pinouts, B-1
 - DB-9 connector (table), 2-9
- power cables (table), 1-1
- power cables, part numbers (table), 1-2
- power inhibit switch LED indicator, 2-8
- power supply
 - connecting to, 2-5

- remote voltage monitoring and inhibiting interface, 2-9
- replacing, 3-3
 - configuration, 3-4
 - connecting safety ground, 3-4
 - connecting to power source, 3-4
 - installation, 3-4
 - removal, 3-3
- voltages at voltage monitoring connector (DB-9) (table), 2-9
- power up, testing, 2-5
- PXI differential star trigger specifications (PXIe-DSTARA, PXIe-DSTARB, PXIe-DSTARC), A-9
- PXI Express configuration in MAX, 2-11
- PXI Express peripheral slots, description, 1-7
- PXI Express system controller, 2-5
 - figure, 2-6
 - installing in a NI PXIe-1075 chassis (figure), 2-7
- PXI local bus, routing, 1-9
- PXI star trigger specifications, A-9
- PXI star, routing, 1-8
- PXI-1 configuration in MAX, 2-12
- PXIe_DSTAR, routing, 1-8
- PXIe_SYNC_CTRL, 1-12
 - specifications, A-9
 - using as restart (figure), 1-12

R

- rack mount kit dimensions (figure), A-13
- rack mounting, 2-4
 - kit, 1-5
- related documentation, *vii*
- remote voltage monitoring and inhibiting interface, 2-9
- replacing the power supply, 3-3

S

- safety and caution notices, 2-1
- safety ground, connecting, 2-4
- safety specifications, A-5
- service interval, 3-1
- setting fan speed, 2-4

- slot blocker
 - installation, 2-4
 - kit, 1-5
- specifications
 - acoustic emissions
 - sound power, A-5
 - sound pressure level (at operator position), A-5
 - backplane
 - 10 MHz system reference clock (PXI_CLK10), A-7
 - 100 MHz Reference Out BNC, A-8
 - 100 MHz system reference clock (PXIe_CLK100 and PXIe_SYNC100), A-8
 - CE compliance, A-6
 - chassis cooling, A-3
 - dimensions (figure), A-11, A-12
 - electrical
 - AC input, A-1
 - DC output, A-2
 - electromagnetic compatibility, A-6
 - environmental
 - operating environment, A-4
 - storage environment, A-4
 - external clock source, A-8
 - mechanical, A-10
 - PXI differential star triggers (PXIe-DSTARA, PXIe-DSTARB, PXIe-DSTARC), A-9
 - PXI star trigger, A-9
 - PXIe_SYNC_CTRL, A-9
 - rack mount kit dimensions (figure), A-13
 - safety, A-5
 - shock and vibration, A-5
 - system reference clocks, A-7
 - static discharge damage (caution), 3-1
 - system controller slot
 - description, 1-6
 - pinouts
 - XP1 connector (table), B-5
 - XP2 connector (table), B-4
 - XP3 connector (table), B-3
 - XP4 connector (table), B-3

- system reference clock, 1-10
 - default behavior (figure), 1-10
 - specifications, A-7
- system timing slot
 - description, 1-8
 - pinouts
 - TP1 connector (table), B-8
 - TP2 connector (table), B-7
 - XP3 connector (table), B-6
 - XP4 connector (table), B-6

T

- testing power up, 2-5
- trigger bus, 1-9

U

- unpacking the NI PXIe-1075 chassis, 1-1

V

- voltage monitoring connector. *See* DB-9 connector
- voltages at voltage monitoring connector (DB-9) (table), 2-10