

**Using the Venable  
Windows Software 4.0  
For  
MODEL 3120**

**Venable Instruments  
4201 S. Congress, Suite 201  
Austin, TX 78745**

**512-837-2888**

**[www.venable.biz](http://www.venable.biz)**

# TABLE OF CONTENTS

TOPICS	PAGE
<b>System Overview</b> .....	1
<b>New Features of the Venable System Version 4.0 Software</b> .....	2
<b>Installation Procedure for Venable Model 3120 Analyzer</b> .....	3
<b>“Sanity check” – Measure the Output of the Oscillator</b> .....	5
<b>Tutorial No.1 – Measure an RC Low-Pass Filter Transfer Function</b> .....	6
<b>Tutorial No.2 – Model of an RC Low-Pass Filter Transfer Function</b> .....	8
<b>Toolbars and Drop-Down Menus</b> .....	11
<b>Keyboard and Mouse Shortcuts</b> .....	12
<b>Measuring a Feedback Loop Transfer Function</b> .....	14
<b>Measuring a Modulator (Plant) Transfer Function – Open Loop Method</b> .....	21
<b>Measuring a Modulator Transfer Function – Closed Loop Method</b> .....	24
<b>Design of a Feedback Amplifier from the Modulator Transfer Function</b> .....	25
<b>Calculation of the Predicted Overall Feedback Loop Transfer Function</b> .....	32
<b>Loading and Saving Settings</b> .....	34
<b>Display Documentation Features</b> .....	35
<b>Installing the Venable Matlab files</b> .....	38
<b>Exporting Data from the Venable Software</b> .....	39
<b>Importing Data into the Venable Software</b> .....	45
<b>Description and Uses of Accessories</b> .....	49
<b>ADVANCED TOPICS</b>	
<b>Calibration of Oscilloscope Probes for Flat Frequency Response</b> .....	50
<b>Measurement of the Loops in a Multi-Loop Power Supply</b> .....	52
<b>Measurement of the Pieces of a Loop</b> .....	56
<b>Measurement of the Impedance of Components versus Frequency</b> .....	58
<b>Measurement of the Input and Output Impedance of Power Supplies</b> .....	65
<b>Circuit Modeling Overview</b> .....	69

## System Overview

The Venable Windows Software in combination with the Model 3120 Frequency Response Analyzer (FRA) is a complete frequency response modeling and measurement system. The hardware portion consists of the FRA for making measurements of gain, phase, and voltage versus frequency and various accessories for coupling the FRA to the electrical, mechanical, or thermal system under test. The software portion runs on any personal computer using Microsoft Windows NT 4/2000/XP/2003. The Model 3120 is controlled through a National Instruments GPIB board. The software also contains a simple spice-like modeling program for modeling the AC frequency response of circuits. Model results and test results are in the same format and can be displayed simultaneously for easy comparison. Compensation amplifier synthesis software lets the user achieve the exact feedback loop bandwidth and phase margin desired on the first try. "File Math" software allows any kind of mathematical function on any one or two transfer functions. Data can be saved, recalled, and printed in the form of graphs on any Windows-compatible printer in black-and-white or color if the printer has that capability. Graph types supported are voltage vs. frequency (log-log), gain and phase vs. frequency (semi-log), reactance vs. frequency (log-log with lines for constant capacitance and inductance), and Nyquist (log outside of the unity gain circle and linear inside the unity gain circle).

The Venable software is protected against illegal copying and use. In order to run, first it must be activated. There are three ways to activate your Venable software:

- If you have an internet connection, you may use the "Electronic Registration" button to validate your serial number. This is the fastest and easiest method.
- If you don't have an internet connection but you have e-mail access, you can send your site code along with your name, company name, address, phone number, and Venable frequency response analyzer serial number (on the back of the instrument) to [authorize@venable.biz](mailto:authorize@venable.biz). Your site code is shown when you select "Show site code" from the "License" menu.
- Otherwise, you can call Venable Instruments with your site code at 512-837-2888.

## New Features of the Venable System Version 4.0 Software

Several new features have been implemented in the Venable System Version 4.0 Software:

- The software has been updated to work with the newly introduced wider bandwidth Venable 3215 and 3225 analyzers.
- The Agilent (HP) 3577A/B network analyzer can now be controlled with the Venable system software. The HP3577 combined with the Venable system software creates a completely new, easier to use frequency response measurement system.
- A new Venable Reader is available for free download from the Venable website. The Reader lets anyone view, print, export, or examine data and also save screen captures of Venable plots.
- The new release provides the ability user to print out a schematic of a synthesized error amplifier on a sheet of paper with component values and reference designators. This function creates a useful hardcopy reference when working with hardware in a lab environment.
- The capability to import and export data to Mathcad has been added to the software.
- The software now allows the user to select the correct GPIB interface to communicate with the analyzer on PC's with multiple GPIB cards installed.

Several existing problems have been eliminated:

- Registration and activation of the Demo software over the Internet is greatly improved with the elimination of the negative serial number problem.
- New updated versions of the Matlab import and export m-files to eliminate data export and import problems.
- The Graph Description text box bug, which caused the mouse to behave erratically, has been fixed.
- The disappearing character bug in the Error Amplifier Synthesis and Circuit Analysis menu has been resolved. The software settings for this menu are now saved and recalled correctly from the default settings (Venpref.txt) file or a user defined settings file.
- The Venable 350 Auto Integration Error bug that caused the program to crash has been corrected.

## Installation Procedure for Venable Model 3120 Analyzer

This is the software and hardware installation procedure for our Model 3120 GPIB controlled analyzer.

1. Before installing the GPIB card in the PC you plan to use, install the National Instruments GPIB card driver software. Close all your programs and insert the National Instruments CD into your CD-ROM drive. The CD should auto-run and the installation window should open up, otherwise browse the CD with Windows Explorer and double-click on Setup. Left-click on Install NI-488.2 Software for Windows. Follow the instructions. You need only the default installation of the software and you do not need to enable DOS.

**Note: Always install the GPIB driver software FIRST. The GPIB card won't work otherwise. You will have to uninstall the software and the card and then re-install them in the correct order.**

2. Turn the computer off, then install the National Instruments GPIB card in the computer. It is available in ISA, PCI, GPIB-USB, and PCMCIA versions. The software for all versions is the same. When you turn the computer back on, it should recognize the GPIB card as part of the boot-up process. The NI-488.2 Getting Started Wizard window will open up in the lower right corner of your screen. If you want to double-check your installation, left-click on "Verify your hardware and software installation". If the installation is correct, your status will be passed in the NI-488.2 Troubleshooting Wizard window when the testing is done. Click on Exit when your status is verified. Skip the rest of the steps by closing the Getting Started window. These steps are not needed.
3. Install the Venable Windows software. Close all your programs and insert the Venable System installation CD into your CD-ROM drive. The Venable System installation program should start up automatically. If it doesn't, open the Control Panel and left click on Add/Remove Programs and then the Install button. Assuming the CD-ROM drive is D, click on OK for D:\Setup. Make sure you have your software serial number at hand and follow the instructions. We recommend accepting the default directory. The user is given an option to install the software and/or the manual. The manual is in Adobe portable document format (pdf) and is compatible with Adobe Acrobat Reader version 4.0 and above. An installation program for Adobe Acrobat Reader version 5 can be optionally installed on the user's hard disk from the Venable System program installation CD or can be downloaded at [www.adobe.com](http://www.adobe.com). If you need to uninstall the software for any reason, use Add/Remove Programs and choose the uninstall option.
4. Verify the software settings are correct. Open the Venable System Software by selecting: Start Menu>>Programs>>Venable 3120 System. A software registration window will appear when opening the Venable System software for the first time. It is suggested that the user register for warranty and upgrade eligibility. The

program will open, after the registration window closes. Select View from the program pull-down menu and click on Settings. Ensure the GPIB address is set at 8, which is the factory default address on your analyzer. Make sure the selected interface name is set to the default GPIB0. In the special case where there is more than one GPIB card or interface installed on the computer, the interface name may have to be changed in order to select the correct card to communicate with the analyzer. Click on OK and select Actions from the program pull-down menu and open the Analyzer Control Menu. Click on the Take Data at Start Freq button to enable the new address setting. When you shutdown the application the new address will be stored in the VenPref.txt file. The Venable Settings window also allows the user to select the default chart to be displayed when the program is opened.

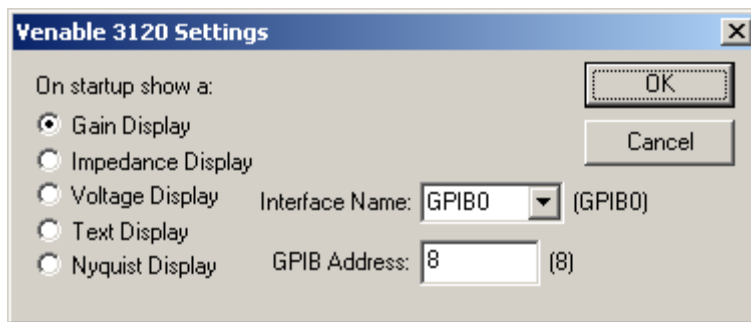

Venable Settings Window

## “Sanity check” – Measure the Output of the Oscillator

After you have connected the hardware and turned the power on and installed the software, a natural question that comes up is “Does it work?” To answer that question, just follow these simple steps:

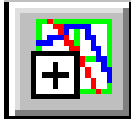
1. Hook up the BNC to Mini-grabber cables that come with the system to the oscillator output and each of the inputs of the FRA. Connect all the black Minigrabbers together and all the red Minigrabbers together.
2. Open the Venable Windows software and click on the Analyzer Control icon on the toolbar, the next-to-last icon just left of the “?” icon. (If you leave the mouse on the icon for a second, it will say “Analyzer Control”). 
3. Set the Start Frequency to 10 Hz, the AC Volts Out to 1 Volt peak, the waveform to Sine, and click Take Data at Start Frequency. The grayed out windows below the Stop Taking Data button on the right side of the Analyzer Control Menu should then read 10 Hz, approximately 0.707 Vrms for each channel, a gain of 0 dB, and phase of 0 degrees for a 3120 analyzer. Data taken by the analyzer will be displayed in the Communication with Analyzer window as shown in the figure below.

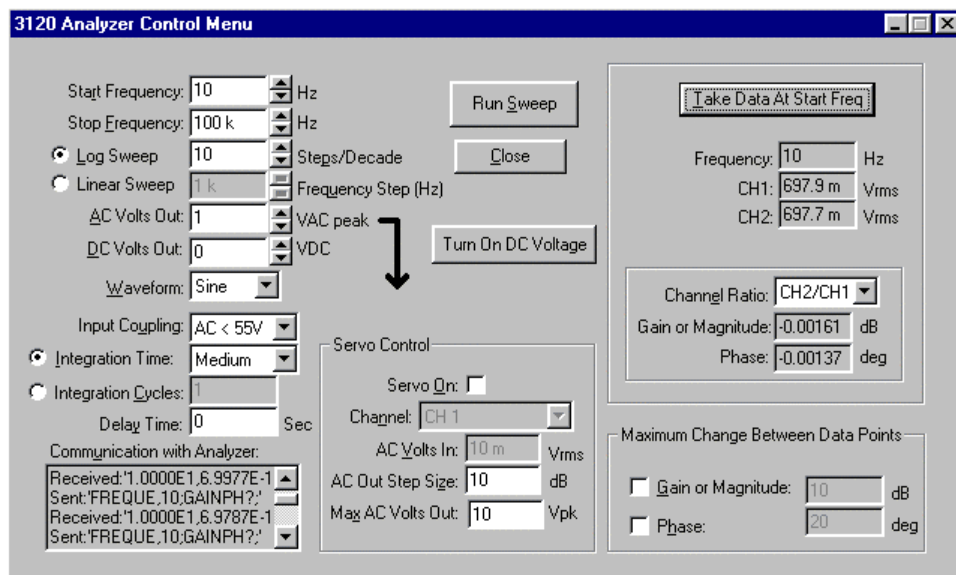

## Tutorial No.1 – Measure an RC Low-Pass Filter Transfer Function

If the “Sanity check” worked out but you still are not convinced, try this as a real-life application of a frequency response analyzer:

1. Take a resistor and capacitor you know the value of and solder them in series. Using the same BNC-Minigrabber cables as before, connect both the oscillator output and channel 1 across both parts with the black (return) lead connected to the capacitor. Connect channel 2 across the capacitor with the black (return) lead connected the same place as the other two black leads. Calculate the corner frequency of the filter from the formula  $f=1/2\pi RC$ . If you don't want to do that much work, use a 1k resistor and a 0.1  $\mu\text{F}$  capacitor and the corner frequency will be 1.6 kHz.

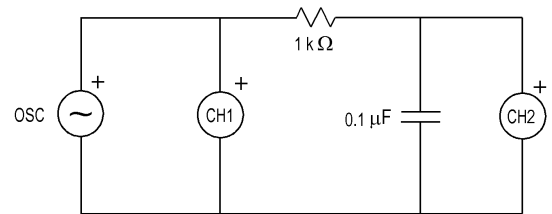

2. Again click the Analyzer Control Icon to open the analyzer control window. Set the sweep from approximately 2 decades below the corner frequency to approximately 2 decades above the corner frequency (10 Hz to 100 kHz if you use 1k and 0.1  $\mu\text{F}$ ). Select Log Sweep, 10 Steps per Decade, 1.414 volts peak AC or 1 Vrms, 0 volts DC, sine wave, Integration Time: Medium, and 0 Delay Time. Click on Run Sweep.

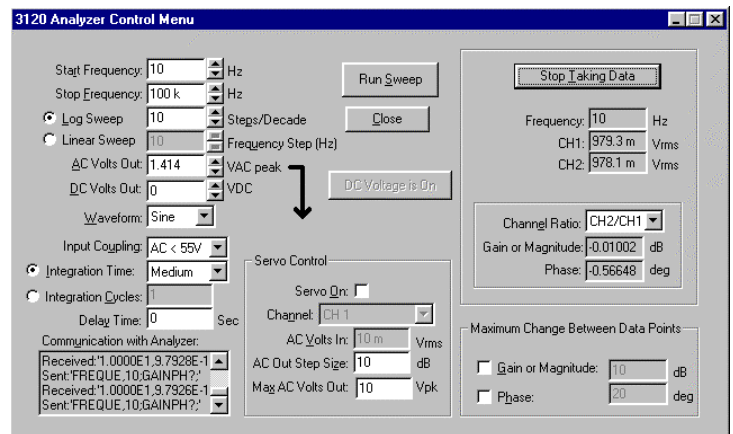

3. The Data Set Properties window will open, as shown below giving you the choice of output node number (channel number), input node number (channel number), and scale factor. The default settings Output Node=2, Input Node=1, and Scale Factor=1 are correct for this measurement. When you have selected the desired variable values, click on “Close”. The window will close and the analyzer will start taking data over the selected frequency range

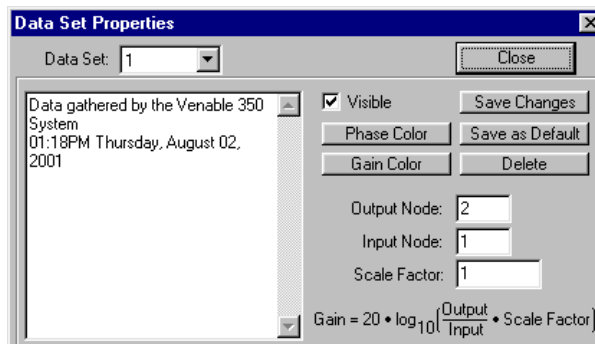



- The sweep will start. The analyzer control window will not minimize automatically. You may want to move or minimize it so you can see the plot of the data being taken in real time. The resulting gain plot should be flat at 0 dB out to the corner frequency, then fall at a -20 dB per decade slope thereafter. The phase should be 0 degrees at low frequency, -45 degrees at the corner, and asymptotically approach -90 degrees at high frequency. If this works, you can be certain that the equipment is connected and functioning properly.

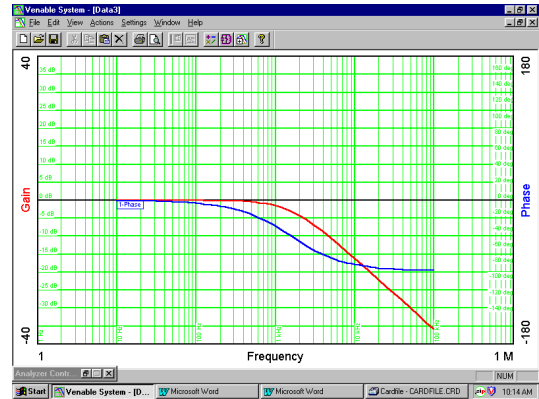

Measured transfer function of low pass R-C filter

## Tutorial No.2 – Model of an RC Low-Pass Filter Transfer Function

As a simple example of how the modeling portion of the software works, an easy thing to do is model the transfer function of the low-pass RC filter corresponding to the test in Tutorial No. 1. If you actually did the test, you can overlay the test and model data to see how close you came.

1. To start the process, click on the “Error Amps and Circuits” Icon, the one just to the left of the Analyzer Control Icon. When that window opens, select the “Circuit (CKT) Model” tab. If there is anything in the text box, delete it and type in the text below:

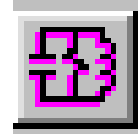

2.

```
V 0 0 1
R 1 0 1
R 1 2 1K
C 2 0 0.1U
```

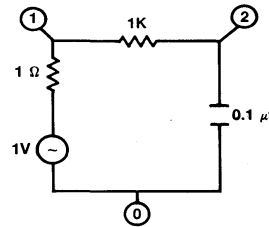

3. For the record, the first two lines represent a fixed voltage source with a magnitude of 1 volt and an internal resistance of 1 ohm, connected from node 1 (the input) to node 0 (ground). The third line represents a 1k resistor connected from node 1 (the input) to node 2 (the output). The final line, line 4, represents a capacitor connected from node 2 (the output) to node 0 (ground) with a value of 0.1 microfarads. The analysis will be done from node 1 to node 2. The internal resistance of the source does not matter since it only changes the absolute magnitude of the voltage on nodes 1 and 2, not the ratio.

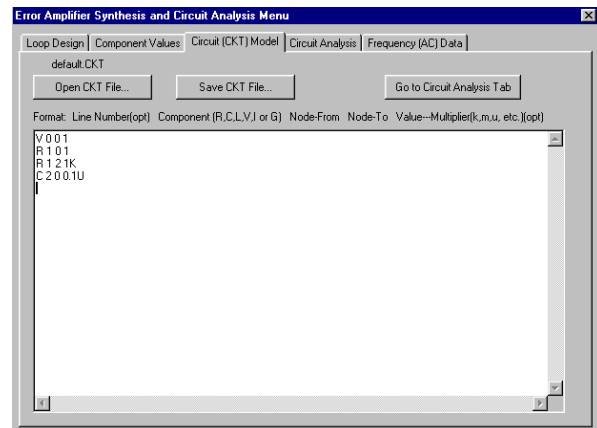

4. After entering the above net list, click the button labeled “Go to Circuit Analysis Tab”. Select the desired Max and Min Frequencies (the same ones you used for the test), the nodes to analyze (1 and 2), and Log Sweep at 10 Steps per Decade. When all variables are correctly entered, click the “Compute AC analysis from CKT” button. You will be sent automatically to the “Frequency (AC) Data” tab. An ASCII text result file will be displayed in Venable Standard Format, which is 5 columns: Frequency, Node number, Voltage (volts), Voltage (dB), and Phase (degrees). There will be a row for

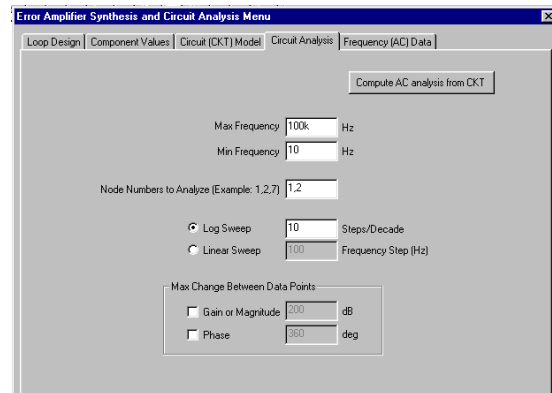

each node selected at each frequency. There is no fixed limit on the size of the circuit or the number of nodes being analyzed. The maximum size is dependent on the available memory in your computer.

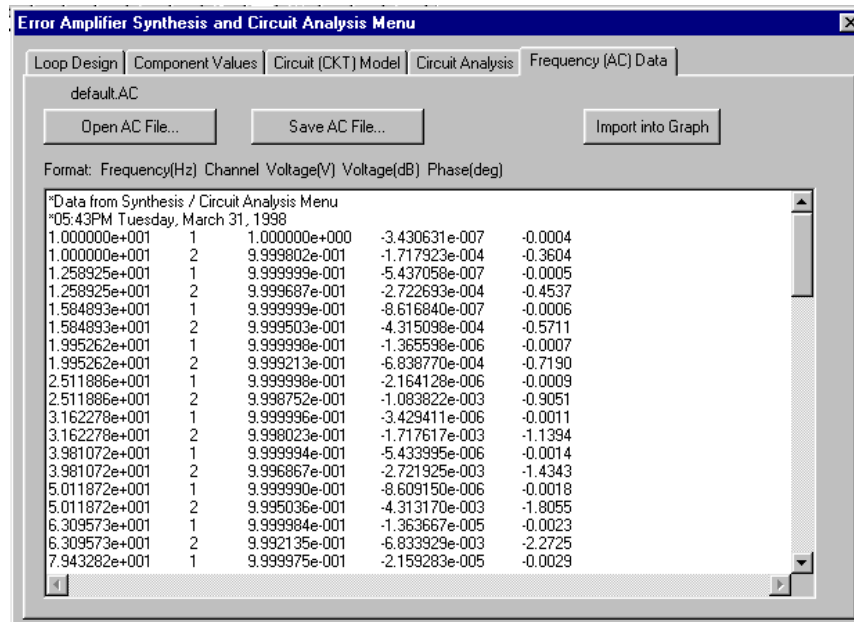

- Click on the “Import into Graph” tab. For Gain or Impedance Displays, the Data Set Properties window will open giving you the choice of output node number, input node number, and scale factor. Choose Output Node=2, Input Node=1, and Scale Factor=1. Once you have selected the desired variable values, click “Save Changes” and “Close”. The window will close and the transfer function of the low-pass RC filter will be displayed on the graph.

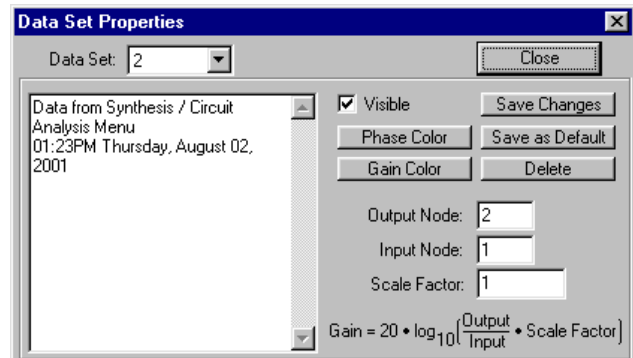

- If you did the test first, both plots will be on the graph. The test data will be labeled 1-Gain and 1-Phase. The model data will be labeled 2-Gain and 2-Phase. If you entered the correct values for the R and C, the two sets of data should virtually overlay each other. The up and down-arrow keys select and toggle through the data sets displayed on the screen in ascending and descending order, respectively. You can change the properties of a data set by using the up and down-arrow keys to select the data set and then pressing the short cut key “D” to open the Data Set Properties window. The number of the data set you selected will appear in the Data Set scroll box. You may select another data set and it’s properties by clicking on the Data Set scroll box arrow and selecting that data set number. You can document any data set by entering a description in the text window. Other data set properties you may alter are scaling, channel ratio, gain or phase color, visibility or you may

delete a data set. When you are done click “Save Changes” and “Close”. The data can now be documented for printing. Select a data set you wish to display information on and then press the short cut key “T”, an editable text box will open (this is the same text window that is displayed in the Data Set Properties window). You may also wish to display the values of the gain/phase data at a particular frequency with a slide bar. Press the short cut key “B” to create a slide bar, then left-click and drag the slide bar to the frequency of interest. A particular data set can have multiple slide bars if needed. The Data Description and Slide Bar windows may also be moved anywhere on the chart that is convenient before printing.

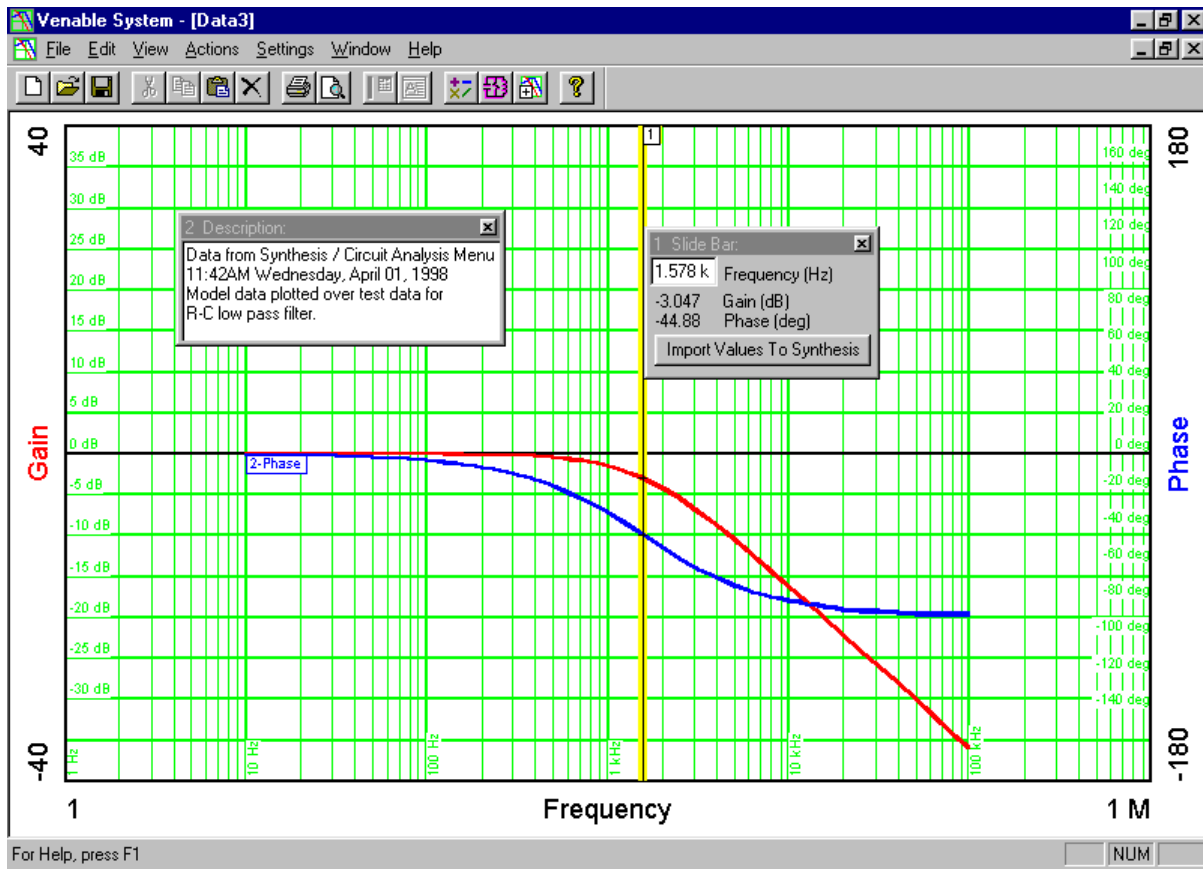

RC Low Pass Filter Model Data Plotted Over Test Data

## Toolbars and Drop-Down Menus

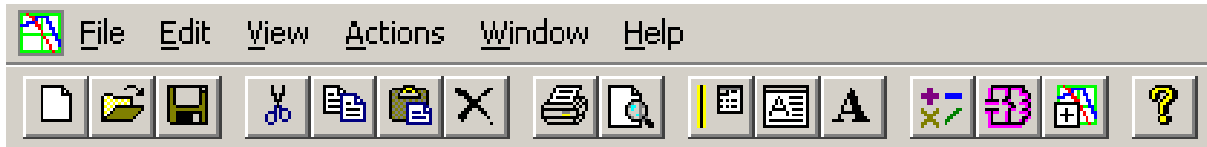

The toolbar is shown above. The nine icons on the left are Windows standard icons, New (plot), Open (plot file), Save, Cut, Copy, Paste, Delete, Print, and Print Preview. The seven icons on the right are (left to right):

- 1) Add slide bar
- 2) Add Data Description text box
- 3) Add Graph Description text box
- 4) Transfer Function Math Menu
- 5) Error Amps Synthesis and Circuit Analysis Menu
- 6) Analyzer Control Menu
- 7) Help

To see the functions available on the drop-down menus (File through Help), click on the Help menu and then click on Venable Help or click the Help icon. You can click on the individual menus when the Help window opens. An index of these is shown below:

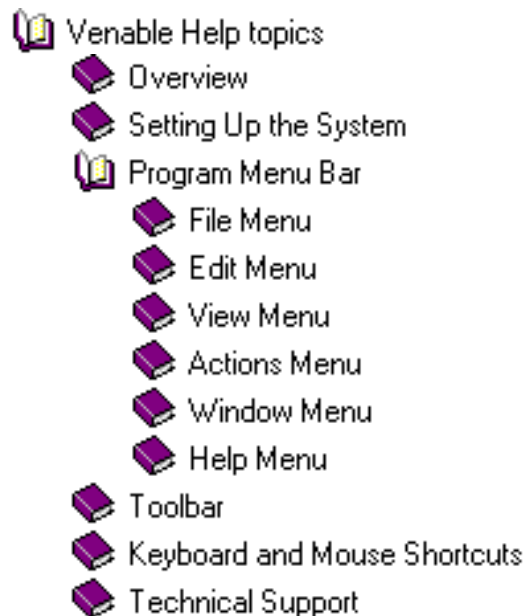

The user can press the F1 key for context sensitive help on an active window, menu, or dialog box. The help window will open at the appropriate topic.

## Keyboard and Mouse Shortcuts

Like any Windows program, you can hold down the Alt key and hit any underlined letter to activate that pull-down menu. Many of the standard Windows Edit Menu control key functions also work, for example:

Ctrl+A	Select All Data Sets
Ctrl+C	Copy Data Set
Ctrl+N	New Plot File
Ctrl+O	Open Plot File
Ctrl+P	Print Plot File
Ctrl+S	Save Plot File
Ctrl+V	Paste Data Set
Ctrl+X	Cut Data Set

Additional Edit Menu keyboard functions have also been created to manipulate data sets on the plot.

Del	Delete (with the option to hide or cancel) Data Set(s)
Ctrl+L	Show All Data Sets
Ctrl+Del	Hide Data Set(s)
Up-arrow key	Select the first Data Set if none is selected and/or toggle through the displayed Data Sets in ascending order
Down-arrow key	Select the last Data Set if none is selected and/or toggle through the displayed Data Sets in descending order

A number of single key commands have been implemented as Venable Software Menu keyboard shortcuts, for example:

A	Analyzer Control Menu
B	Add Slide Bar
D	Data Set Properties
G	Graph Properties
H	Toggles Data Set number visibility
I	Toggles Graph Title visibility
L	Toggles Graph Legend visibility
M	Math Menu
R	Add Random Data
S	Circuit Analysis and Synthesis Menu
T	Show Data Text Description

The Slide Bar has arrow key shortcuts associated with it.

Left or Right-arrow key	Moves the slide bar left or right between the data points taken by the analyzer.
Ctrl+ Left or Right-arrow key	Finds the 0 dB crossing point (phase margin) if it exists.
Shift+ Left or Right-arrow key	Finds the 0 degree, +/-90 degree, or the +/- 180 degree phase points (inductance, resistance, capacitance, or gain margin) if they exist.

The Analyzer Control Menu has keyboard shortcuts associated with it.

Up or Down-arrow key	Increments the AC Volts Out control up or down respectively by the number of decibels entered in the AC Out Step Size control text box.
Page Up or Page Down key	Moves the DC Volts Out control up or down respectively by 10mV increments.

Besides the keyboard shortcuts, there are mouse short cuts.

- 1) Click on any open area of a graph to deselect all data sets.
- 2) Click on any point of any data set to select it.
- 3) Ctrl+click to select multiple data sets.
- 4) Shift+click on a first and last data set to select the first and last data sets and all the data sets in between.
- 5) Double click on any point of any data set to open the Data Set Properties window.
- 6) Double click on an open area of the graph to open the Graph Properties window.
- 7) Right-click when a single data set is selected or when a text window is active to get the pop up-menu for Show All, Select All, Copy, Paste, Hide, and Delete.
- 8) Click and drag any window or text box to move it.
- 9) Click and drag the side or corner of a text box to resize it.
- 10) Click and drag a Slide Bar to move it.

## Measuring a Feedback Loop Transfer Function

The classical way to measure a feedback loop transfer function is to break the loop at some point, terminate the input with the output impedance, terminate the output with the input impedance, drive a small AC signal into the input and measure the ratio of the output to the input. In SPICE analysis, the input is frequently set at 1 volt and the output voltage is then plotted directly as gain since the denominator of the ratio has a constant value of 1. In real life, this measurement approach is virtually impossible since the loop gain is usually very high at low frequency and it is difficult to keep the input stable enough to prevent the output from swinging wildly from limit to limit.

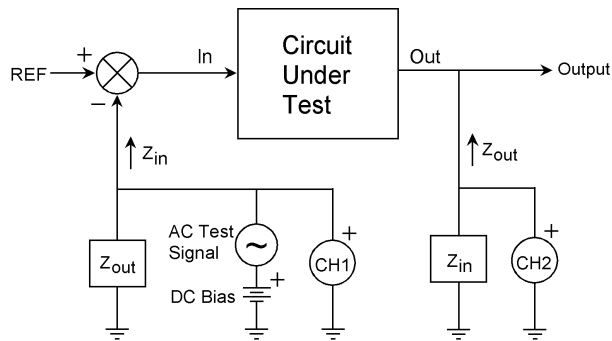

Classical Method

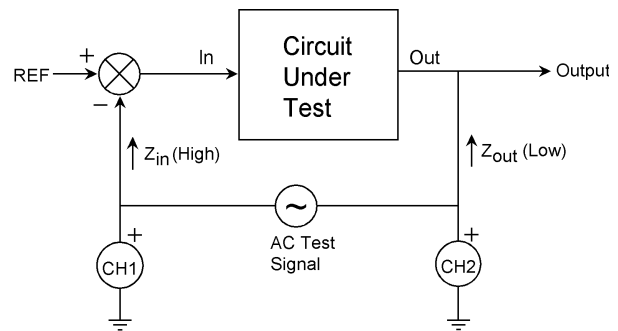

Venable Method

We avoid this difficult measurement situation by finding a place where the loop is confined to a single path (also a requirement in the classical method) and a place where the signal comes from a low-impedance point and drives a high-impedance point. This impedance condition minimizes the error caused by not properly terminating the input and output. We then insert a small resistor into the feedback loop (small compared to the input impedance of the loop). Finally, we connect a floating AC source (the output of a transformer) across the new resistor and drive the primary of the transformer with a sinusoidal voltage source. This converts the resistor into a floating sinusoidal error voltage in series with the feedback loop. This voltage modulates the operating point of the entire circuit.

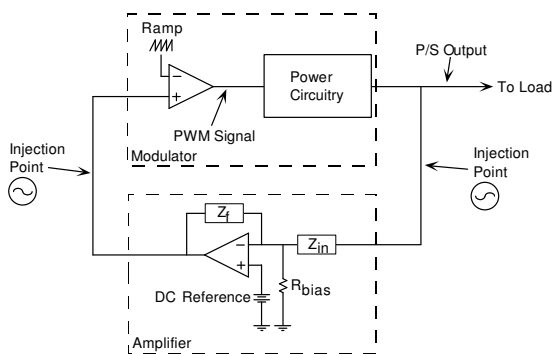

Injection Points

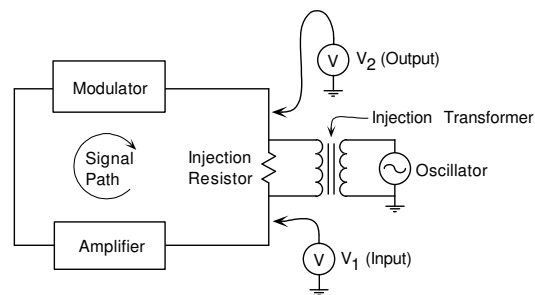

Injection Technique



Once the operating point is modulated, it is easy to measure the voltage to ground from any point in the circuit. The difficult part is that the only signal that matters is the voltage at the frequency of the injected error voltage, which may be a few millivolts in the presence of volts of noise. That is where our superior Frequency Response Analyzer comes in. It uses true Fourier Integral analysis (as opposed to the less-accurate Fast Fourier Transform) to accurately measure amplitude and phase of small signals buried in large amounts of noise. Loop gain is the ratio of the voltage out of the circuit to the voltage into the circuit. The amplitude of the various voltages varies widely with frequency, but the absolute values are not important, only the ratio and relative phase angle.

In the rare case where the impedance ratio of input to output is not sufficiently high, a correction factor can be applied to the data to correct for the impedance condition.

$$A_{\text{actual}} = \frac{A_{\text{measured}} + \frac{Z_{\text{out}}}{Z_{\text{in}}}}{1 + \frac{Z_{\text{out}}}{Z_{\text{in}}}}$$

There is also a “dual” of the voltage injection method that is useful when the input impedance is much lower than the output impedance. This involves injecting a current into the loop instead of a voltage and measuring the ratio of the currents on either side of the injection point instead of the voltage. These two test techniques are shown in the figures below, and the current injection technique is used in one of the injection point examples.

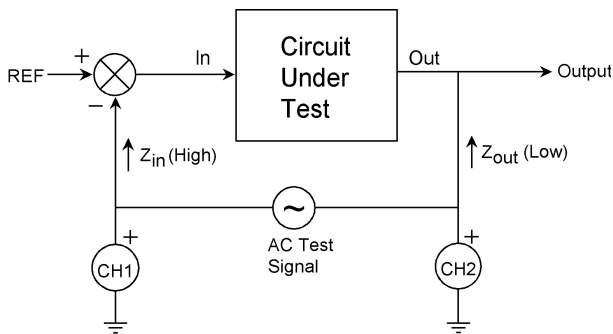

**Voltage Mode Injection**  
 Use when  $Z_{in} \gg Z_{out}$   
 Gain = CH2/CH1  
 This is the normal injection method

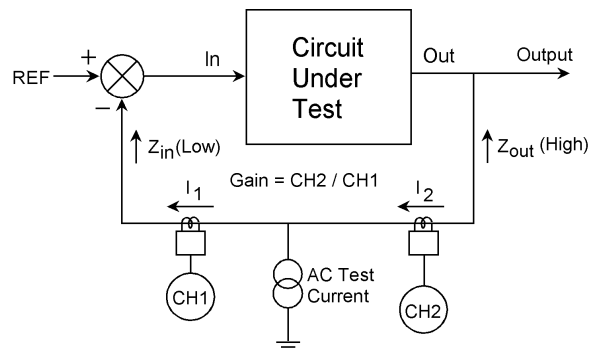

**Current Mode Injection**  
 Use when  $Z_{in} \ll Z_{out}$   
 Gain = CH2/CH1  
 “Dual” of normal method

Here is a step-by-step description of how to measure a feedback loop transfer function:

1. Find a place in your circuit where the loop is confined to a single path, comes from a low impedance, and drives a high impedance. In a power supply, the most reliable place that meets these criteria is the point where the resistor or network (labeled  $Z_i$  in the figure below) connects to the output of the power supply, typically a large-value electrolytic capacitor.

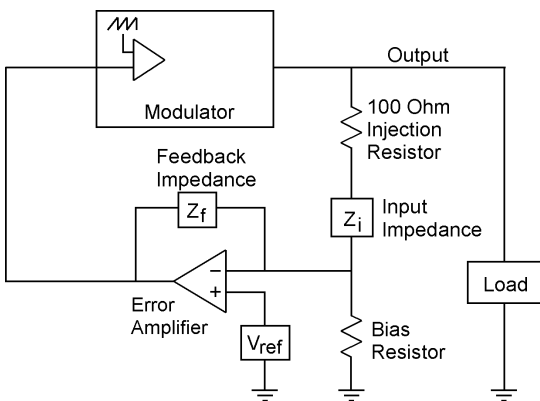

Injection in top of feedback string.

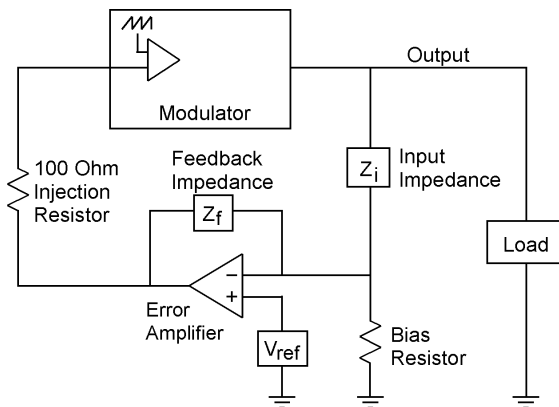

Injection between amplifier and modulator.

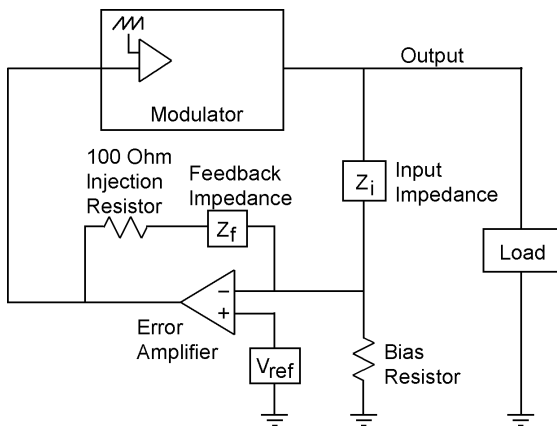

Inject in feedback of error amplifier. Always available but usually noise sensitive. Also works on circuits with TL431's and optocouplers.

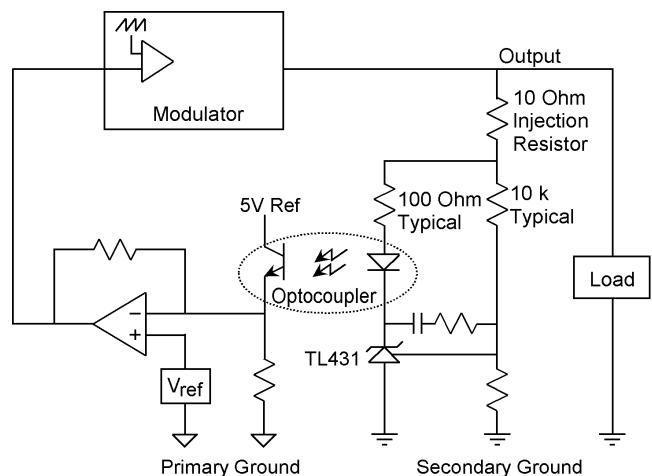

Injection in circuits using TL431. Make sure injection includes both the "fast loop" through the diode and the "slow loop" through the resistive divider string.

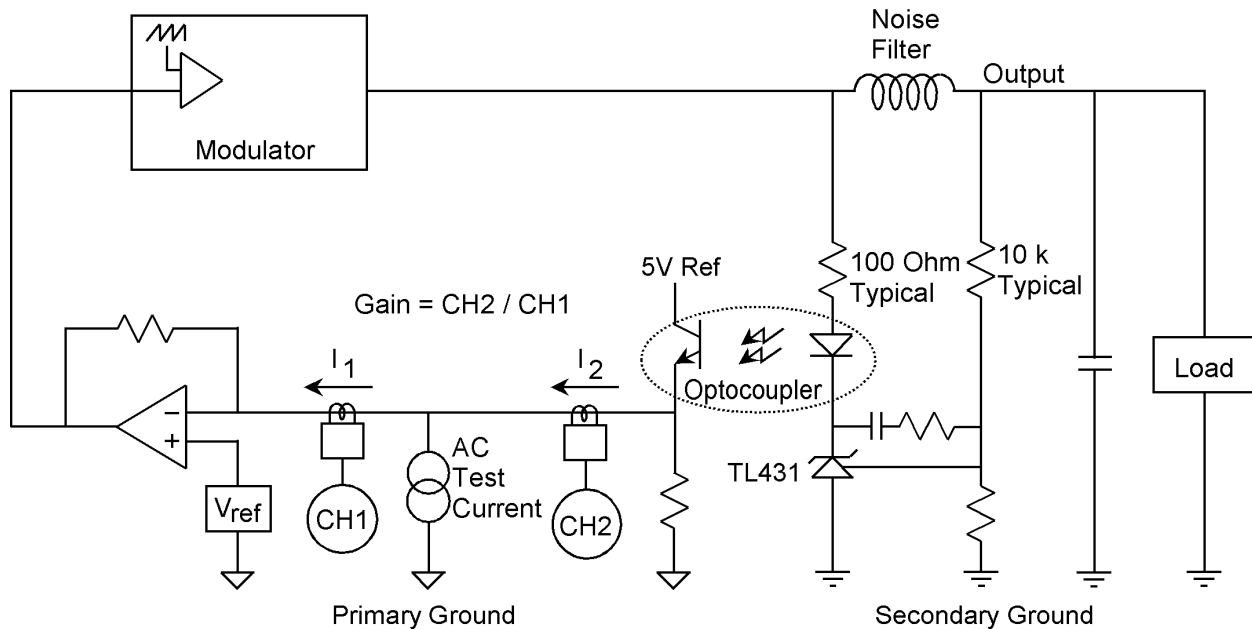

Current injection works in many difficult measurement situations. This method requires two current loops and two current probes but no resistor inserted in the circuit. Gain is determined by the ratio of two currents instead of the ratio of two voltages. A high-value resistor (typically 10k) is used to couple the oscillator output to the test point between the two current probes. Use the DC offset capability of the oscillator to bias the DC level to match the common mode voltage of the error amplifier, usually 2.5 volts, so the DC operating point of the circuit is not disturbed.

2. At the injection point, lift the resistor or network off the printed circuit board and insert a low-value resistor between the network and the output bus. The preferred value of this injection resistor is 100 ohms. Lower resistance values can be used, even down to 1 ohm, but the signal levels and the bandwidth of the injection transformer may suffer. You can judge the effect for yourself by noting the quality of the data, especially the data at frequencies far below or above the loop crossover frequency. On future designs, think about designing the injection resistor in as a permanent part of the circuit. The cost is negligible and it allows you to perform a loop frequency response test any time you want to.
3. Three points are necessary to measure loop gain: the two sides of the injection resistor and signal ground. The connection used to measure signal ground should preferably be very near the ground of the DC reference voltage, typically the ground pin of the PWM control chip. If these three points are not all accessible with Minigrabber clips, solder test points to the circuit as required.
4. Using three of the BNC-BNC cables provided, connect the Oscillator, Channel 1, and Channel 2 of the Frequency Response Analyzer to the corresponding three BNC connectors on a Bode Box Model 200-002 injection transformer.

- Using the black, brown, and red Banana-Minigrabber cables provided, connect each banana plug end to the correspondingly colored banana jack on the same Bode Box Model 200-002 injection transformer.
- Connect the black Minigrabber to signal ground near the ground of the reference voltage. This point must be within rated signal ground to chassis ground voltage of your particular analyzer.
- Connect the brown Minigrabber to the point where the injection resistor ties to the error amplifier input resistor or network. This voltage must be within rated input to signal ground voltage of your particular analyzer.
- Connect the red Minigrabber to the point where the injection resistor ties to the power supply output bus (or equivalent point in your circuit). This voltage must be within rated input to signal ground voltage of your particular analyzer.

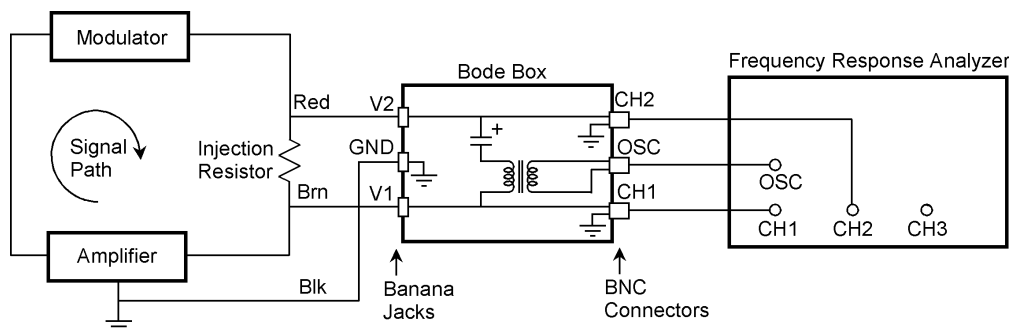

- Turn your circuit on and make sure it is operating properly.
- A highly recommended step is to connect a two-channel oscilloscope to the same signals that Channel 1 and Channel 2 are connected to. This will allow you to monitor the amount of signal injected into the loop and determine if there is any clipping or distortion of the sinusoidal injection signal. The theory behind this measurement requires that the output be continuously and linearly proportional to the input. If this is not true, the results will not be valid.

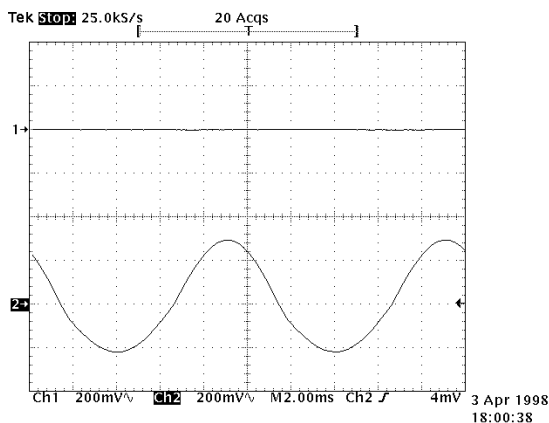

Distorted sine wave indicates overdrive.

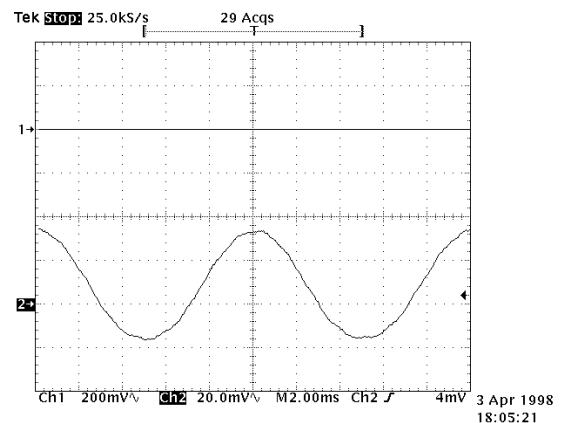

Undistorted sine wave is desired.

11. Open the Venable software and click on the Analyzer Control icon. Set the variables as desired. Typical values are:

Start Frequency	10 Hz
Stop Frequency	90 kHz (10-20% less than your switching frequency)
Log Sweep	10 Steps/Decade
AC Volts Out	1
DC Volts Out	0
Waveform	Sine
Input Coupling	AC < 55V
Integration Time	Medium
Delay Time	0 Sec
Servo	Off
AC Out Step Size	10 dB
Max AC Volts Out	10 Volts peak
Channel Ratio	CH2/CH1
Max Gain Change	Unchecked
Max Phase Change	Unchecked

12. Click on the “Take Data at Start Freq” button. There should be communication with the analyzer, with the data showing up in the text box in the lower-left corner of the Analyzer Control window. The “Gain” and “Phase” boxes (on the right side of the window under “Channel Ratio”) should read reasonable values.

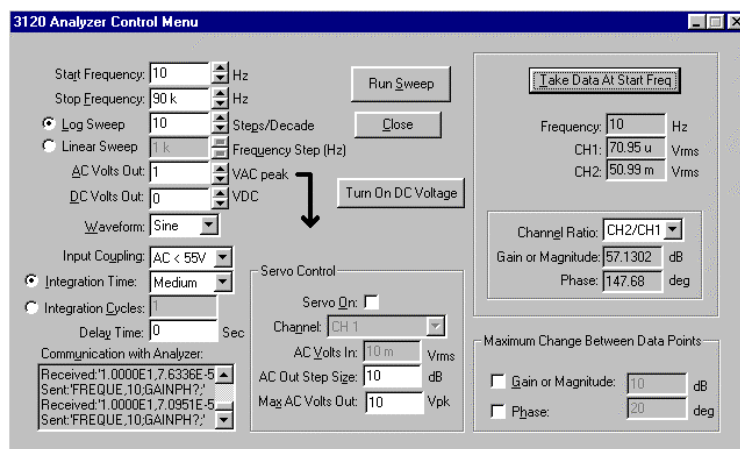

13. If everything looks OK, click the “Run Sweep” button. The system will automatically sweep from the start frequency to the stop frequency at the specified number of steps per decade. You may want to move or minimize the Analyzer Control window so you can see the data being presented in real time.

14. When the sweep is complete, you can minimize or close the Analyzer Control window. The data just taken will automatically be “selected” and each data point will show as a black dot. When you

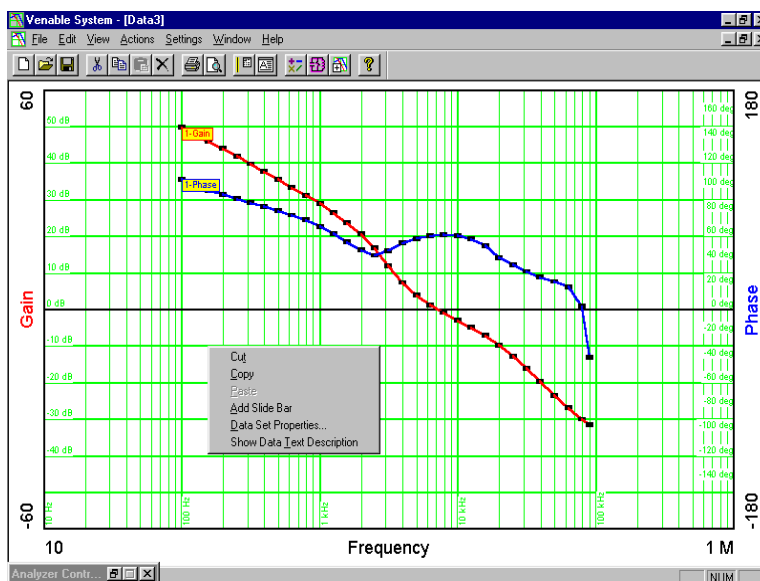

click the right mouse button, you will see a number of options you can do with the selected data set. You can cut, copy, or paste the data onto another graph, even one with a different format. You can add a slide bar. This is a vertical cursor you can move with the mouse. The values of Gain and Phase can be read directly in the related text box as you move the slide bar. You can have as many slide bars as you want, on as many data sets as you want. You can move the text boxes to any desired position. Another option is to change the data set properties. You can change the output node number, input node number, scale factor, or color of either curve. You can edit the Data Text Description, as well as, hide, unhide, delete, or change to a different data set. The final option is called "Show Data Description" under the View program menu. This will open a text box keyed to the data set by set number. You can enter any desired information in the box to document the data set. There can be one box for every data set. All text boxes will print as shown on the screen. The Print Preview button is on the icon bar.

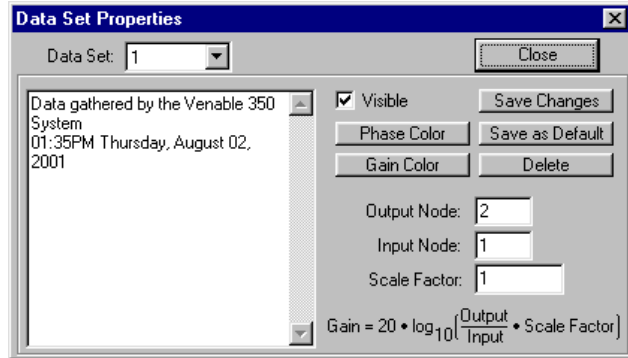

## Measuring a Modulator (Plant) Transfer Function – Open Loop Method

We use the words “Modulator”, “Plant”, and “Control-to-output transfer function” synonymously. These terms refer to the gain from the output of the error amplifier to the output of the system. This gain block typically has a fixed low-frequency gain. High frequency gain falls off at a -1 (-20 dB/decade) or -2 (-40 dB/decade) slope depending on the characteristics of the circuit. Because the gain at low frequency (including DC) is fixed, it is possible to use a DC voltage to bias the operating point to achieve a desired system output. By superimposing a small AC voltage on the DC bias voltage, the operating point of the modulator can be varied. The transfer function of this gain block can then be measured by connecting frequency selective voltmeters (the inputs of the Frequency Response Analyzer) to the input and output of the circuit and sweeping the modulation frequency across the desired frequency range. The output of the Venable Model 3120 Frequency Response Analyzer is designed to deliver DC and swept frequency AC voltage simultaneously. The inputs are designed to measure voltage at the frequency of the output and reject all other frequencies and DC.

Here is the step-by-step procedure for measuring the control-to-output transfer function:

1. The first step is to set up the circuit to be controlled by the output of the FRA. There are three ways to do this. If the error amplifier is a high output impedance transconductance amplifier, the output can be biased high and the output of the FRA used directly to control the operating point. If the error amplifier has a conventional low impedance output but has an input common-mode range at least equal to the voltage swing needed in the output to control the system, the error amplifier can be wired as a buffer follower. If the error amplifier has a conventional low impedance output and a relatively narrow input common-mode voltage range that does not encompass the entire output voltage swing required, the error amplifier can be wired as a gain stage and there is complete freedom of operating point. If in doubt, this third method will work in any situation. The three methods are shown in the nearby figures.

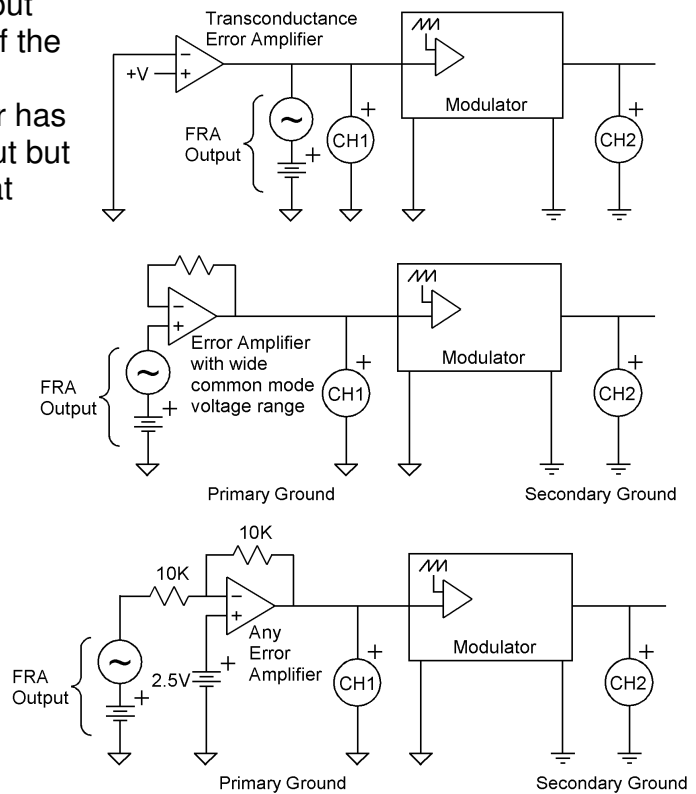

- The next step is to adjust the DC voltage for the desired output of the system. This can always be done if the system has a fixed gain at low frequency. It may be simpler to use a DC lab power supply or a pot across the +5 V reference voltage from the PWM chip to set the bias voltage initially since they are easy to adjust.

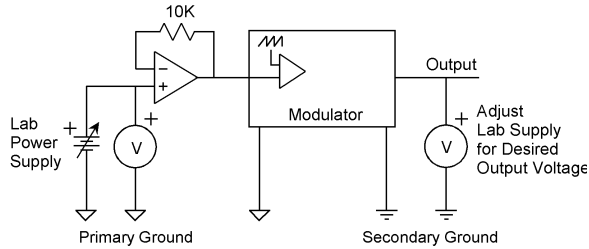

Adjusting operating point with laboratory power supply.

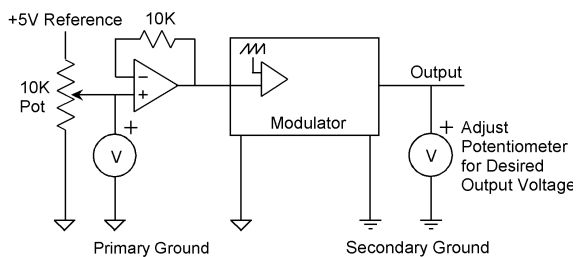

Adjusting operating point with pot across 5V reference of PWM chip.

The DC voltage can then be read with a voltmeter and the FRA output DC voltage pre-set to the approximate operating point. To set the DC output voltage of the FRA, open the Analyzer Control menu and set the “DC Volts Out” to the desired value. Then click the “Turn DC Volts ON” button to set the FRA output to that DC value. Once the approximate operating point is set, it is easy to increment the DC voltage from the FRA to “tweak” the system output to the desired value. The buttons next to the DC voltage setting box increment the DC voltage in 10 mV increments. When the analyzer control window is minimized, the PageUp and PageDown keys increment the DC voltage in 10 mV increments as they did in our DOS software. The DC output voltage is not affected by the sweep.

- If you haven’t already done so, connect Channel 1 of the FRA to the input of the modulator (the error amplifier output) and Channel 2 of the FRA to the output of the modulator (the system output). Use the furnished BNC-Minigrabber cables unless the system under test is affected by the capacitance of the cables. If it is, use a 10:1 scope probe on both Channel 1 and Channel 2. (See the section on calibrating probes in the advanced applications portion of this manual.)
- In the Analyzer Control window, set the AC volts to a small number, typically between 1 and 10 millivolts depending on how much you want to modulate the operating point. If you are not sure, start low and raise the voltage slowly while monitoring the amount of modulation you are injecting. When you click the “Take Data at Start Freq” button, the FRA will output that small signal superimposed on the DC voltage. The modulator output will be the modulator input multiplied by the modulator gain, therefore the ratio of output voltage to input voltage is the modulator gain.
- To get the modulator transfer function, click the “Run Sweep” button in the Analyzer Control window. The measurement system will then automatically sweep the frequency of the AC portion of the FRA output signal from the start frequency to



the stop frequency at the specified number of steps per decade and display the gain vs. frequency and phase vs. frequency data on the graph.

6. This data can then be used to automatically design the error amplifier compensation for the desired loop bandwidth and phase margin.

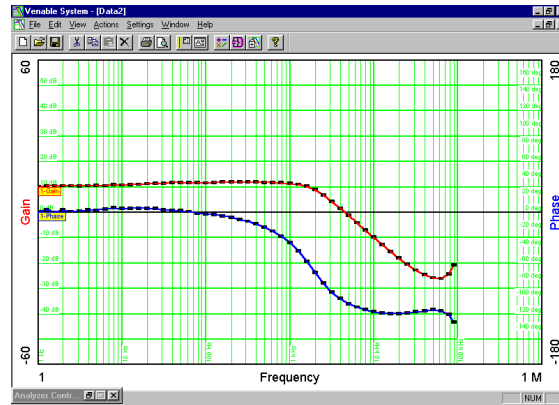

## Measuring a Modulator Transfer Function – Closed Loop Method

The open loop method described in the previous section is the best method for going directly to the desired system performance without any trial-and-error. Quite often, however, the loop is already closed and the objective is to “fix” the loop rather than design it. In this case, the modulation signal is injected as an error voltage in series with the feedback loop exactly as it is when measuring loop gain (see section on measuring loop gain).

The principal difference between measuring the modulator and measuring the loop is that the simple connection where the injection signal is connected automatically to the FRA inputs through internal connections in the Bode Box injection transformer is not used.

The Bode Box injection transformer is still needed to inject the signal to vary the operating point, but separate BNC-Minigrabber or scope probe connections are used to measure the modulator input and output voltage, just as in the open loop case.

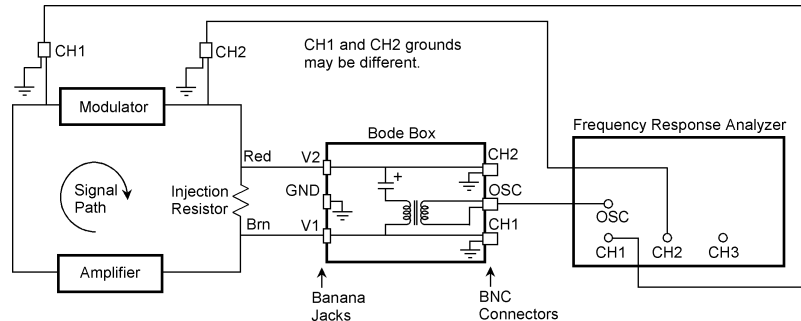

The advantage of measuring the modulator transfer function while the system under test is operating closed loop is that the bias adjustment procedure described in the previous section is not needed. The disadvantage is that the signals are generally noisier and the accuracy is not as good, especially at high frequency.

# Design of a Feedback Amplifier from the Modulator Transfer Function

Once you have measured (or modeled) the modulator transfer function, you can have the Venable System software design the compensation amplifier for your desired loop. Here are the steps:

1. With the modulator (also called plant or control-to-output) transfer function displayed as a gain-phase graph and selected, click the Slide Bar icon or right-click anywhere on the open graph and click "Add Slide Bar". Note that data is "selected" by clicking anywhere on either curve of the data set or pressing the right- or left-arrow keys to toggle through the various data sets displayed. Also note that the Slide Bar option is not available if more than one data set is selected since the Slide Bar is keyed to a particular data set.

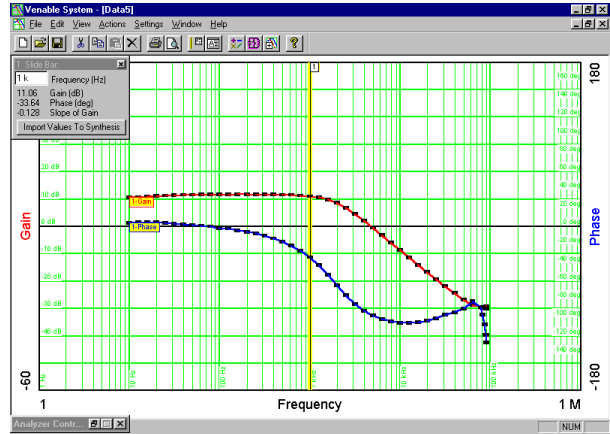

2. When the Slide Bar is added to the modulator transfer function data set, click and hold it with the left mouse button then move it to the desired loop bandwidth. In choosing loop bandwidth, remember that the response time of a system to a transient is approximately the reciprocal of the loop bandwidth. Also remember that the theoretical bandwidth limit of a switching or sampled data system is half the switching or sampled data rate. As a practical matter, even though it is theoretically possible to cross the feedback loop over at half the switching or sampling frequency, a more achievable number will be in the range of 10-20% of the switching or sampling frequency.

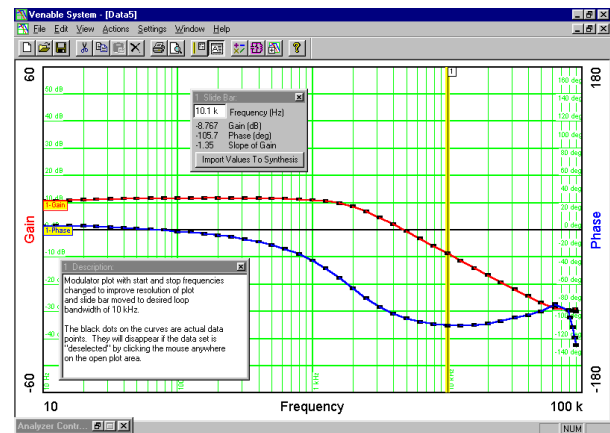

3. After choosing the desired loop bandwidth and moving the Slide Bar to that frequency, note that the text box associated with the slide bar has a button labeled "Import Values to Synthesis". Click that button. This will open the "Error Amplifier Synthesis and Circuit Analysis Menu" window and transfer the loop crossover frequency to that window together with the modulator gain and phase measurements at that frequency.

The screenshot shows the 'Error Amplifier Synthesis and Circuit Analysis Menu' window. It contains several sections:
 

- Loop Design:** Includes buttons for 'Open Design File', 'Save Design File', and 'Compute Component Values'.
- Design files:** A note stating 'Design files (\*.DES) capture all loop design parameters and current component values'.
- Overall Loop Circuit:** Fields for 'Crossover Frequency' (101.1 k Hz) and 'Desired Phase Margin' (60 degrees).
- Control-to-Output (or Modulator) Circuit:** Fields for 'Gain at Crossover Frequency' (8.75748 dB) and 'Phase at Crossover Frequency' (-105.703 degrees).
- Error Amplifier Circuit:** Includes a checked 'Circuit is Inverting' box, 'Amplifier Topology' set to 'Regulator', and fields for 'Input Resistor (R1)' (10 k Ohms), 'Input Voltage' (3.3 VDC), 'Reference Voltage' (5 VDC), and 'Common Mode Voltage' (2.5 VDC).
- Op Amp Selection:** A dropdown menu set to 'default.AMP', with fields for 'Bandwidth' (3 M Hz), 'Gain' (50 dB), 'Transconductance' (3.3 m Mhos), and 'Internal R' (1 k Ohms).

4. In the Error Amplifier Synthesis and Circuit Analysis Menu window there are a number of choices to make:
- Phase margin – Choose a value between 45 and 72 degrees. We recommend 60 degrees as a good starting point.
  - Maximum circuit complexity – Type 1 is a simple integrator, type 2 has a single zero-pole pair, and type 3 has two zero-pole pair. If the modulator transfer function is flat at the chosen crossover frequency, choose type 1. If the modulator transfer

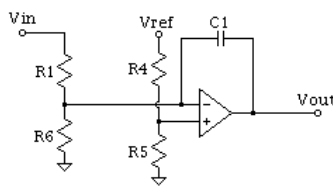

Type 1

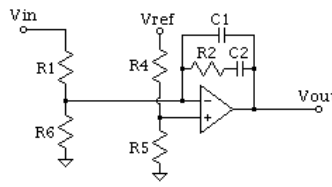

Type 2

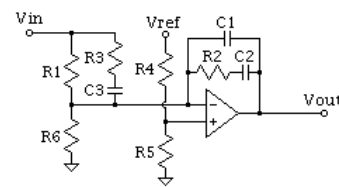

Type 3

function is falling at a  $-20$  dB/decade slope at the chosen crossover frequency, choose type 2. If the modulator transfer function is falling at a  $-40$  dB/decade slope at the chosen crossover frequency, choose type 3. An error message box on the next (Component Values) tab will tell you if you chose an unachievable combination.

- “Circuit is Inverting” check box – check this box if the modulator inverts (output is 180 degrees out of phase with the input) at low frequency. Leave it unchecked if the modulator output is in phase with the input at low frequency. If the gain is flat at low frequency (it should be), the circuit will be either inverting or non-inverting. It will not have some in-between phase value if the test was performed correctly.

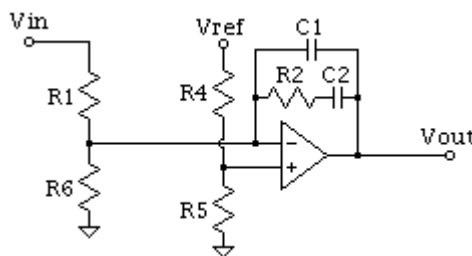

Inverting amp for non-inverting modulator

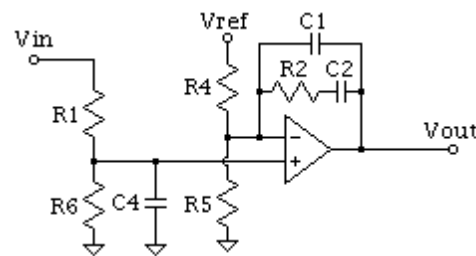

Non-Inverting amp for inverting modulator

- Amplifier Topology – Regular is a conventional low output impedance amplifier where the feedback compensation components are connected from error amplifier output to inverting input. Transconductance is a high output impedance amplifier where the feedback compensation components are connected from error amplifier output to signal ground.

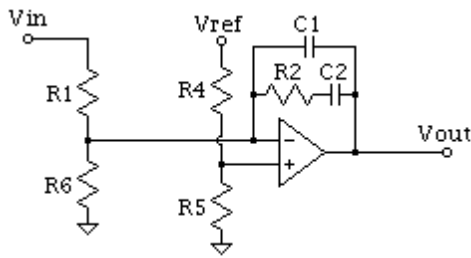

Regular

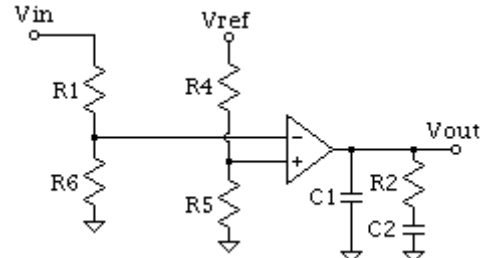

Transconductance

- e) Input Resistor (R1) – this is the value of the resistor, which connects from the modulator output to the error amplifier input. All feedback compensation components scale from this resistor. If you want some other component in the compensation network to have a particular value instead, choose a round number like 1k for R1 and note the value of the component you want controlled. Then change the value of R1 to make the other component come out the value you want. All resistor values will be directly proportional to R1. All capacitor values will be inversely proportional to R1.
  - f) Input Voltage – this is the output voltage of the modulator or plant (which becomes the input voltage of the compensation amplifier).
  - g) Reference Voltage – this is the value of the reference voltage used to control the output of the modulator. It could be a temperature-compensated zener diode, the reference pin of a control integrated circuit, or an external reference or control voltage.
  - h) Common Mode Voltage – this is the voltage at the inputs of the compensation amplifier. Both the inverting and non-inverting inputs of the amplifier will be at the same voltage if the circuit is operating properly. The synthesis program will determine the proper value of the resistive divider string from Reference Voltage to the amplifier inputs so that the DC resistance driving each amplifier input is the same. This is necessary for best amplifier performance.
  - i) The only other entry is the error amplifier internal characteristics. Gain and bandwidth come from the data sheet. If you do not know the amplifier output impedance, use 1k. For transconductance amplifiers the gain, bandwidth, and transconductance are specified on the data sheet.
5. After you have entered in all the design values and choices, if you want to save the values for later use click the “Save Design File” button and you will be prompted for a file name and location. If not, go ahead and click the “Compute Component Values” button. This will send you to the next (Component Values) tab with the error amplifier compensation component values calculated already.

6. At the Component Values tab, first check the “Error messages” text box to see if anything needs fixing. If not, choose the preferred tolerances for components in your company, then click the “Round off Component Values” button to round off the values to the nearest standard value for the specified tolerance. We do not use the tolerance in calculations, so you can enter a larger tolerance if you want more standard values even though you plan to use a closer tolerance part in the final design. For example, you may prefer to have the system choose a 1k resistor instead of 910 ohms, so you can choose 10% or 20% tolerance instead of 5% which might give you a value like 910 ohms. The information boxes in the lower right quadrant of the window tell you where the poles and zeros of the amplifier transfer function will be. You can also change any particular component value if a similar value is more readily available and the new pole-zero locations will be calculated and displayed so you can judge the impact of the change on overall loop performance. Once the component values satisfy your criteria, click on the “Make KCT model from component values” button.

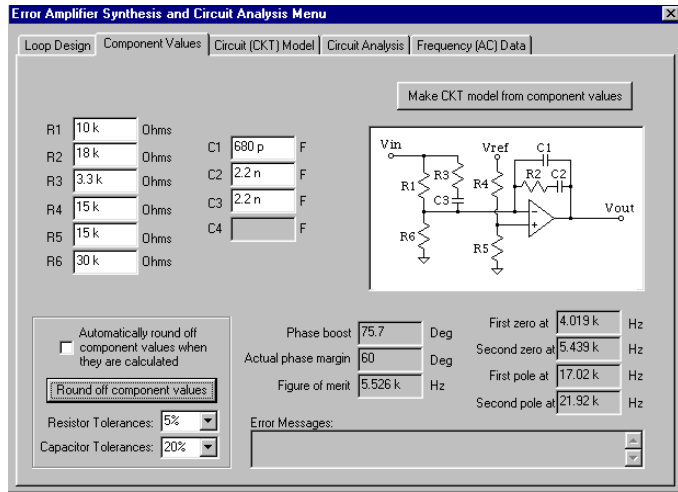

7. This will send you to the “Circuit (CKT) Model” tab and display a SPICE-like net list of the model of the compensation amplifier. See the schematics and models below for reference. This net list can be edited. Components can be added or removed or their types, values or connections changed. The one thing that cannot be done is that a node cannot be removed (skipped in the node number sequence). Node numbers must be sequential starting with zero (ground). If you change a circuit enough to remove a node, simply connect a resistor from the node to ground. It will not have any effect on the circuit and the analysis will still run properly. When you are happy with the net list, click the “Go to Circuit Analysis Tab” button and you will be sent to the next (Circuit Analysis) tab.

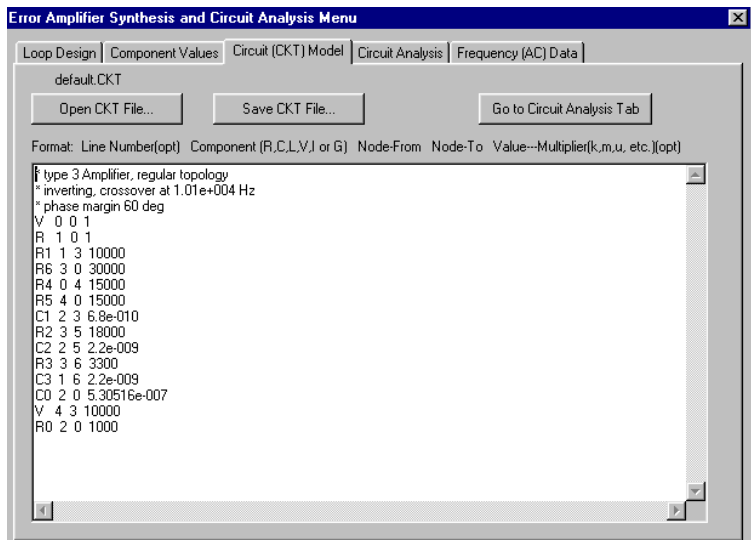

The figures below represent the amplifier schematics and models. The node numbers and component reference designators are correct. The schematics and models differ slightly for transconductance amplifiers, non-inverting amplifiers, and amplifiers where the input voltage and reference voltage have different polarities.

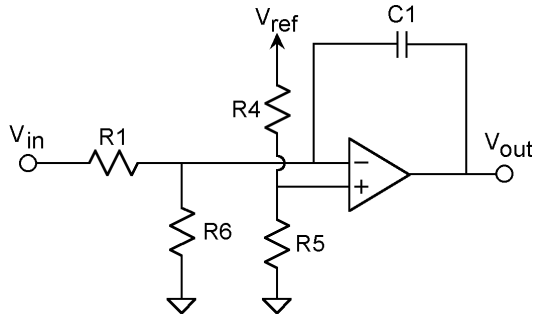

Type 1 Amplifier Schematic

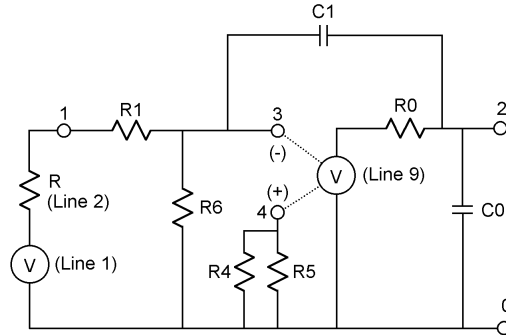

Type 1 Amplifier SPICE Model

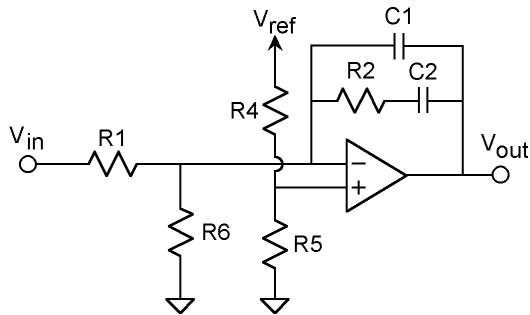

Type 2 Amplifier Schematic

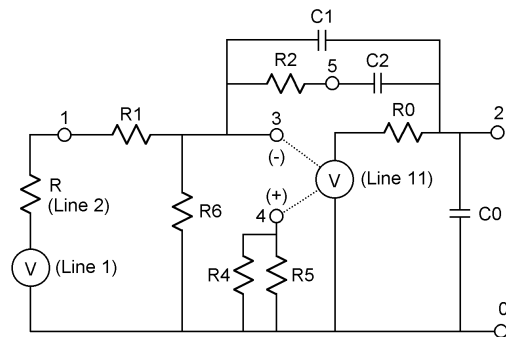

Type 2 Amplifier SPICE Model

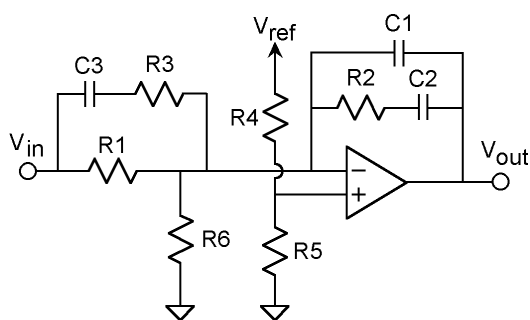

Type 3 Amplifier Schematic

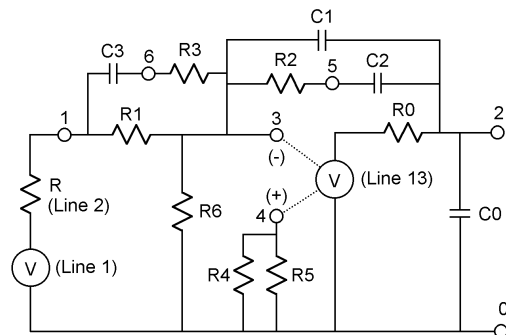

Type 3 Amplifier SPICE Model

8. The Circuit Analysis tab is where you set up the parameters of the AC analysis of the net list. Choose the maximum and minimum frequency for the analysis sweep, the node numbers you want to save data for (you can save all of them if you want to), whether you want a log or linear sweep and what the resolution of the sweep is, and finally whether or not you want to activate the feature we formerly called “Max Delta Gain/Max Delta Phase”. This feature measures the change in gain and phase from one analysis point to the next, and if the gain or phase change on any node is greater than the amount specified, will cut the frequency step size in half and try again. This can happen a maximum of 5 times (steps/decade x 32) up to a maximum resolution of 2000 steps/decade.

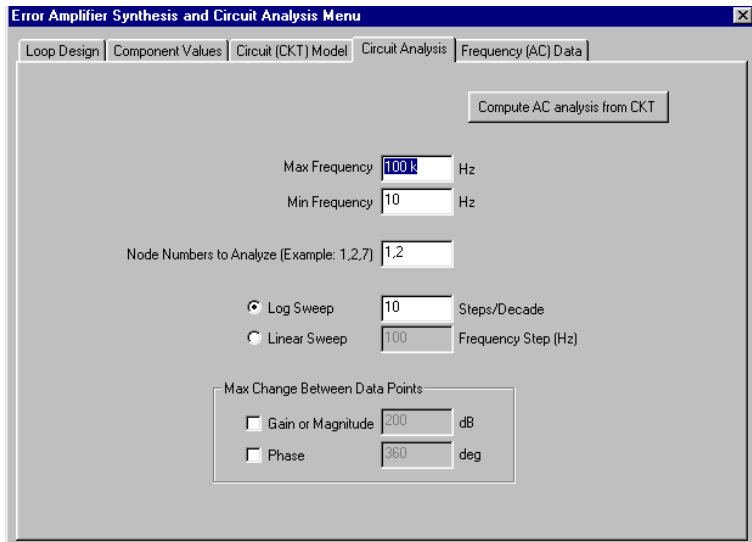

9. When the parameters of the analysis are set to your requirements, click the button labeled “Compute AC analysis from CKT”. This will take you to the final tab, “Frequency (AC) Data”. A brief description of the origin of the data will be at the top of the text display in lines starting with \* (asterisk). Following the comment lines, the data will be displayed in Venable Standard Format which is 5 columns: Frequency, Node number, Voltage (volts), Voltage (dB), and Phase (degrees). There will be a row for each node selected at each frequency.

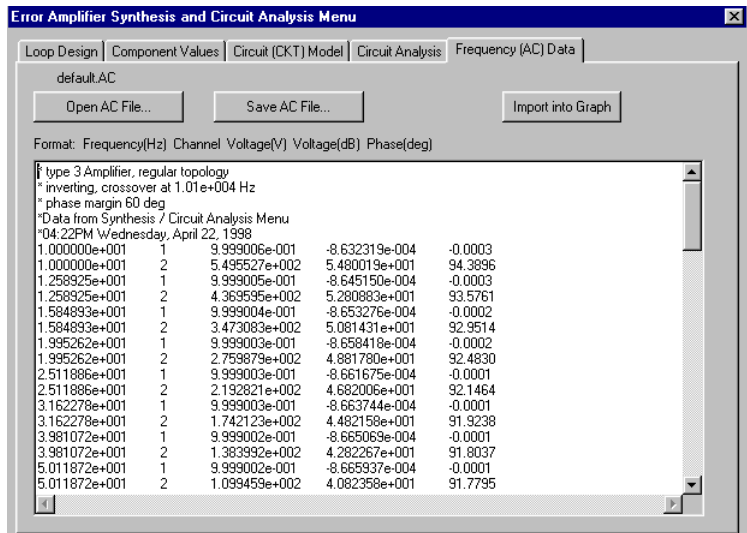

10. From the “Frequency (AC) Data” tab, click the “Import into Graph” button. If you have followed the steps up to here, a gain-phase graph of the modulator transfer function is already displayed and you will only see the second setup window asking you to confirm the output node, input node, and scale factor. Click OK to accept the default values of 2, 1, and 1.



11. After clicking OK, the setup menu will clear and you will see the graph with the amplifier transfer function gain and phase superimposed on the original modulator transfer function. At the desired loop crossover frequency, the amplifier gain should be as far above (or below) the 0 dB gain axis as the modulator gain is below (or above).

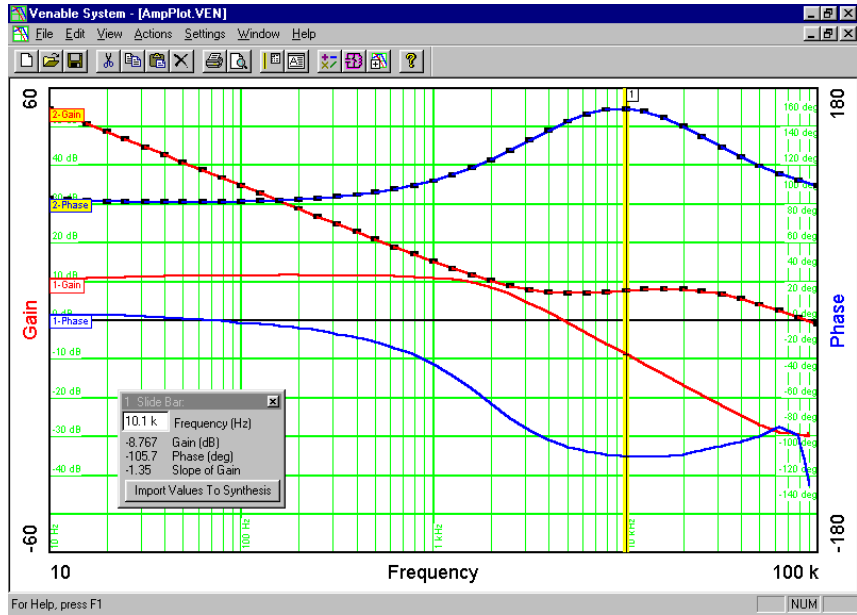

## Calculation of the Predicted Overall Feedback Loop Transfer Function

Before you install the various resistors and capacitors of the compensation network in the circuit, you would probably like to know what the overall feedback loop transfer function will look like. After all, you may want to do some tweaking before you solder everything in. Predicting the loop gain is easy. Here are the steps:

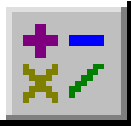
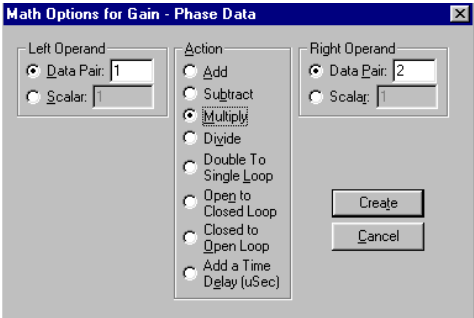
1. Display both the modulator transfer function and the amplifier transfer function on a gain-phase graph. If you followed the steps in the previous sections, they are already displayed. Note the data set number of each of the two data sets (the modulator gain and phase curves are a data set and the amplifier gain and phase curves are another data set).
2. Click on the icon called “Do Math on Data”, the one with the four math symbols on it. In the “Math Options for Gain-Phase Data” window, set the left operand to the number corresponding to one data set and the right operand to the number corresponding to the other data set. This will usually be 1 and 2 if only two data sets are displayed. Select the “Multiply” option, then click the button called “Create”. 
3. When you click the “Create” button, the math window will close and the loop transfer function will appear on the graph as an additional data set. It will be “selected” and you will be able to see the individual data points. The loop gain should cross the 0 dB line at approximately the frequency you chose as the desired loop frequency and the phase margin should be approximately the phase margin you asked for. The differences between actual and desired values are caused by rounding off the component values and by the limitations of the op-amp selected. If you don't round off the component values and you do set the gain and bandwidth of the op-amp at high values, the actual and desired values will be identical. In real life, however, you have to use available components and real op-amps and the predicted results will be very close to the actual measurements. 
4. If you want to document the results, select (click on) only the final gain and phase plots and add slide bars by clicking on the slide bar icon (the one with the yellow vertical line). Slide bars are keyed to data sets so the slide bar icon is available only when one data set is selected. You can have as many slide bars as you want, but two is usually a nice number. You can put one slide bar on gain crossover and the other on phase crossover. That will give you numerical readouts of the loop bandwidth, phase margin, zero phase bandwidth, and gain margin. As a final touch, you can add a text box by clicking on the text box icon (with the “A” on it). A brief description of the source of the data and the time and date it was created are

entered automatically in the box. You can edit or add to this information to document the model and serial number, test conditions, values of the various components, or anything else you think will be of value when you or someone else looks at the plot.

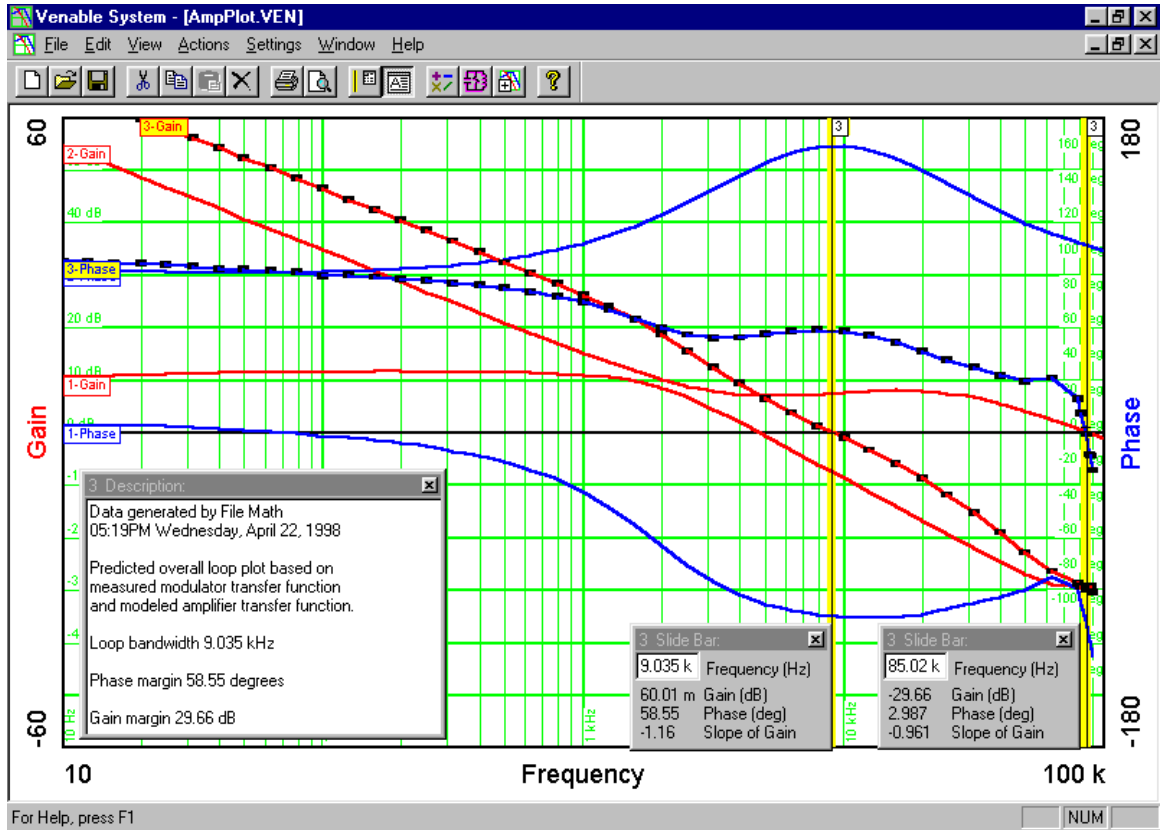

## Loading and Saving Settings

The Venable System software allows the user to save and recall user and/or test-specific Analyzer Control menu settings, the Error Amplifier Synthesis and Circuit Analysis menu entries, and user defined default Data Set Properties. Normally, when the application is closed, the internally saved settings are written to an ASCII text file called VENPREF.TXT located in Venable System directory. The program will create this file if one does not exist in the Venable System directory.

The Analyzer Control menu parameters saved internally in the application after the menu is closed are: Sweep Generator parameters, Input Channel parameters, Servo Control, Channel Ratio and the Maximum Change Between Data Points settings. When saved, the user can recall test-specific Analyzer Control menu settings at a future time.

The Error Amplifier Synthesis and Circuit Analysis menu entries saved internally in the application after the menu is closed are: Loop Design parameters, Component Values, Circuit Model, Circuit Analysis settings, and the Frequency Data. By saving these values, the user can save an entire error amplifier design including simulation data.

The default Data Set Properties saved are: the channel ratio, scale factor, gain or impedance data set colors, and phase colors. Voltage colors for the voltage display are saved separately from the data colors of the other plots. User defined Data Set Properties are saved as defaults by clicking on the Save as Default button in the Data Set Properties dialog box. Any plots opened after a set of defaults has been saved will also have those defaults. Saving these properties reduces the workload, especially, when making a large number of measurements.

To save your settings to a file you must:

1. Close the Analyzer Control Menu and/or the Error Amplifier Synthesis and Circuit Analysis menu to save your settings internally. Save as Default any changes made to the data set properties.
2. Left-click on the Save Settings menu item on the File program menu and save them as a text file to any directory you wish.

To load your saved settings from a file you must:

1. Close the Error Amplifier Synthesis and Circuit Analysis menu or any open data plots before loading your saved settings to avoid any confusion. The settings will not load into these windows if they are open.
2. Left-click on the Load Settings menu item on the File program and select the settings file that you wish to load.

## Display Documentation Features

Several documentation features can be added to the graph displays. Any number of Graph Description text boxes, which are associated with each graph, can be added to the display. This text box is separate from the Data Description text box that records and time stamps the test set up and is associated with each data set. The Slide Bar and its associated window are useful for tracking and displaying data values at a specific frequency. The display can also include a graph title. It can be hidden or unhidden as needed. Finally, a graph legend text box that associates a y-axis label with data set colors may be displayed. It can also be hidden or unhidden as needed. All these documentation features are located under the View program menu.

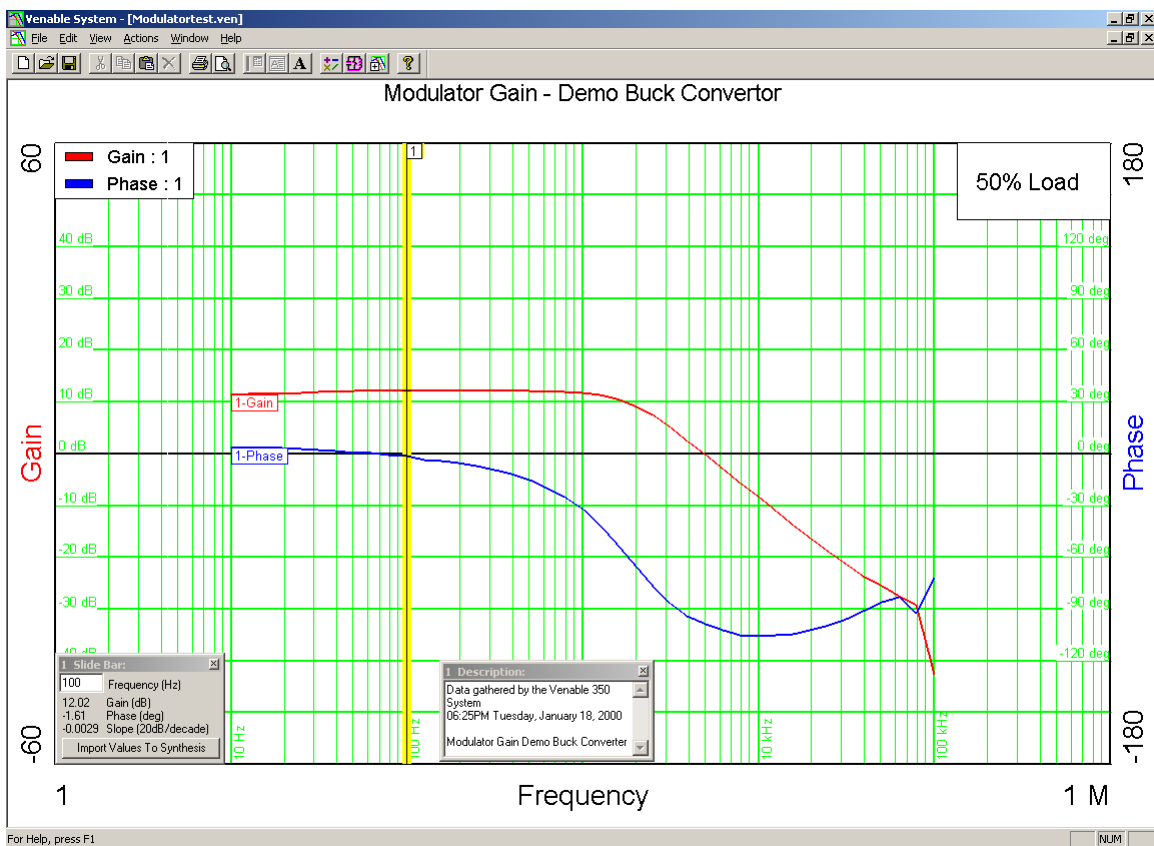

The screen shot above shows the display documentation features for Venable System software plots. Clockwise from the top left are the Graph Legend, Graph Title text box, the Graph Description text box, Data Description text box and the Slide Bar. Also note that the data set number, which is located on the left-hand side of the data set, can be hidden.

### ***Show Data Description***

Displays a text description of the selected data in a pop-up text window. This command is only active when a single data set is selected. This window is useful for documenting the conditions under which the measurement was made such as temperature, load condition, etc. The Venable software always makes two default entries in Data Description text display window: a date-time stamp and the source of the data i.e. the particular type of analyzer or the Synthesis/Circuit Analysis Menu. When you copy a data set, this text description is copied as well. The Data Description is the text header located at the top of the data table in the Text Display window.

### ***Add Graph Description***

Adds a Graph Description text box to the graph display. This text box is useful for describing the graph display. The user can edit or add text by double clicking the mouse on the text box. By right-clicking the mouse on the text box, the user can delete the Graph Description text box, select text justification, or select a new font, font style, size, effects, or color. This text box can be moved or resized by dragging it with the mouse. There is no set limit to the number of Graph Description text boxes that can be opened.

### ***Show Data Numbers***

Shows or hides the display of the number and the identifying text attached to each data set. The data set number and the plot name are located at the top of each data table displayed in the Text Description window.

### ***Show Graph Title***

Toggles the visibility on and off of the title text box at the top of the graph display. The user can edit or add text by double clicking on the Graph Title text box. By right-clicking the mouse on the Graph Title text box, the user can toggle visibility, select text justification, or select a new font, font style, size, effects, or color. This box cannot be moved or resized.

### ***Show Graph Legend***

Toggles the visibility on and off of a text box that identifies the number and colors assigned to each data set when that data set is selected. If no data set is selected the number and colors of the lowest numbered visible data set are displayed. This box may be moved but can't be resized.

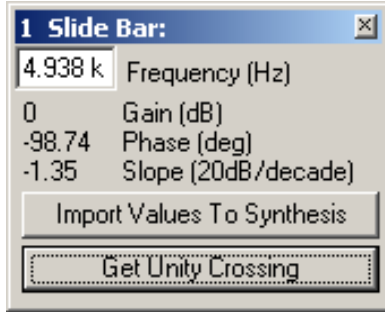

Slide Bar Window

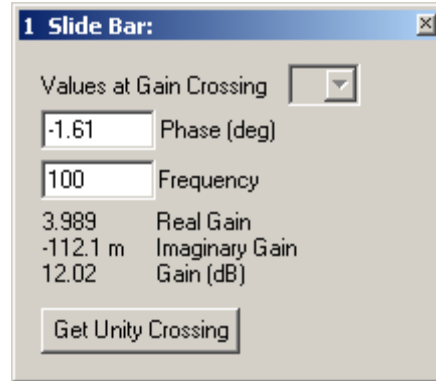

Nyquist Slide Bar Window

### **Add Slide Bar**

The slide bar is useful for tracking and displaying data values at a specific frequency, represented by a vertical line, or in the case of the Nyquist graph a specific phase, represented by a radial line, and a description box. The Add Slide Bar command can only be run when a single data set is selected. More than one slide bar may be opened at one time, either from the same or different data sets. Add Slide Bar is not available in a text display window.

The bar can be dragged using the mouse pointer, and the box will contain the data at the selected frequency or frequency and phase in the case of the Nyquist graph. The frequency or phase can also be typed in, and the line will move to that frequency or phase respectively. Since the slide bar may cross the data set more than once on a Nyquist plot, a colored cursor was added to the plot so the user may determine which data is being read by the slide bar and displayed in the description box. The crossing point on the Nyquist plot can be changed with the Values at Gain Crossing scroll box.

You can use the Left or Right-Arrow key shortcut to move the slide bar left or right between data points taken by the analyzer. The Shift+Left or Right-Arrow key shortcut finds the 0 degree, +/-90 degree, or the +/-180 degree phase points (inductance, resistance, capacitance, or gain Margin) if they exist. The Ctrl+Left or Right-Arrow key shortcut finds the 0 dB crossing point (phase margin) if it exists. The user can also click on the Get Unity Crossing button to find the 0 dB crossing point.

The Import Values To Synthesis button in the description box on the Gain–Phase graph display imports the slide bar values directly into the Error Amplifier Synthesis and Circuit Analysis Menu.

## Installing the Venable Matlab files

Move the Venload.m, Vendlmread.m and Vensave.m files to a directory in the Matlab path or create a directory and place it in the Matlab path. You can also add the C:\Program Files\Venable Inc\Venable 3120 System\ directory to the Matlab path or make it the current directory. See step 2 below.

1. Add the directory to the Matlab path. You can do this by opening Matlab. For Matlab 5 and 6, select Set Path from the File menu. The Path Browser will open and you can add any directory to the Matlab path.
2. Make the C:\Program Files\Venable Inc\Venable 3120 System\ directory the current directory. For Matlab 5, use the CD command to change the current directory i.e. cd 'C:\Program Files\Venable Inc\Venable 3120 System\''. For Matlab 6, select Current Directory from the View menu. The Current Directory Browser will open and you can make any directory the current directory.



## Exporting Data from the Venable Software

The Venable software uses tab delimited ASCII text when exporting or importing data. The Venable software saves data in this form when you select, cut or copy, and paste data to the clipboard or save it to a text file. Data in this form can be easily exported to or imported from Excel, Matlab, or Mathcad applications.

### Venable Data Formats

Venable data can be exported or imported in two different formats. The Voltage or DOS format is the 5-column raw data acquired from each analyzer channel. Data from the DOS versions of the Venable software can be imported and saved using the Voltage format. This format also allows users to examine the raw measurements and do their own calculations on the data. The Magnitude-Phase format is the 3-column text representation of a particular data set plotted on a Venable software plot. The majority of users will find this the most useful format for exporting or importing data. The plotted data set consists of a channel ratio multiplied by a scale factor. The channel ratio and scale factor settings for each plotted data set can be changed and are located in the Data Set Properties for each plot.

1. To view the two different data formats, open up a Venable plot containing plotted data sets.
2. You can observe the data in the two different text formats by going to the Window program menu in the Venable application and selecting Add Text Display.
3. Go to the Edit pull-down menu and if the Voltage Format for Cut/Copy is checked, the data will be displayed in Voltage format. The scale factor will be noted but not multiplied by the data. See the example below.

Gain4.ven: Data 12:

\*Data from Synthesis / Circuit Analysis Menu

\*01:26PM Wednesday, December 04, 2002

\*Gain/Phase: Output Node=2, Input Node=1, Scale Factor=10

*Frequency (Hz)	Channel or Node	Voltage (Volts)	Voltage (dB)	Phase (Deg)
1	1	1	0	0
1	2	3.63637	11.2134	-0.1391
1.25893	1	1	0	0
1.25893	2	3.63637	11.2134	-0.1751

If you uncheck the Voltage Format for Cut/Copy menu item by clicking on it, the data will be displayed in the Magnitude-Phase format. The scale factor will be multiplied by the channel ratio. See the example below:

Gain4.ven: Data 12:

\*Data from Synthesis / Circuit Analysis Menu

\*01:26PM Wednesday, December 04, 2002

*Frequency (Hz)	Gain (dB)	Phase (Deg)
1	31.2134	-0.1391
1.25893	31.2134	-0.1751

### Exporting Venable data using the Clipboard

The Venable plot data including the data header is exported to the clipboard as tab delimited ASCII text. Here are the steps you should follow to export data from the Venable software to the clipboard and to paste the data to another application:

1. Open up the Venable plot containing the data to be exported with the Venable software.
2. Go to the Edit program menu and make sure the Voltage Format for Cut/Copy is unchecked to export data in the Magnitude-Phase format.
3. Select the data set to be exported from the plot by left clicking on the data (Black squares appear on the data set when it's selected and the data set number turns yellow). With a plot selected, different data sets can be scrolled through if there is more than one on a plot by hitting the up and down arrow keys on the keyboard.
4. When the plot to be exported is selected, go to the Edit program menu again and select Copy or use the Ctrl-C shortcut keys.
5. Either open the Circuit Analysis Menu, which is located in the Actions program menu. Left-click on the Frequency (AC) data tab. Right click for the Edit pull-down menu and select Paste or hit the Ctrl-V keys to paste the data into the text window. The file is now in tab delimited ASCII which you can save by clicking on the Save AC File button.
6. Or open up a text editor, like Notepad or WordPad, and directly paste the data into it. Make sure to save the data as a text file in WordPad.
7. Or open up a spreadsheet application like MS Excel and directly paste the data into the workbook.

## Exporting Venable data using Export to Matlab/Mathcad

The Venable plot data is exported to a text file (.dat) as tab delimited ASCII text. This function removes the data header because Matlab arrays and Mathcad input tables do not handle mixed data types. Below are the steps that should be followed to export data from the Venable software to the Matlab or Mathcad.

1. Open up the Venable plot containing the data to be exported with the Venable software.
2. Go to the Edit program menu and make sure the Voltage Format for Cut/Copy is unchecked to export data in the Magnitude-Phase format.
3. Select the data set to be exported from the plot by left clicking on the data (Black squares appear on the data set when it's selected and the data set number turns yellow). With a plot selected, different data sets can be scrolled through, if there is more than one on a plot, by hitting the up and down arrow keys on the keyboard.
4. Go to the File pull-down menu and click on the Export To Matlab/Mathcad menu item. The file Save As pop-up window will open. The data is saved as a tab delimited data (.dat) file with the Venable text header removed. See the example below:

1	31.2134	-0.1391
1.25893	31.2134	-0.1751

## Exporting a Venable Plot as a Graphics File

The Venable can save plots in JPEG graphics format, which can be read by any web browser or easily pasted into Word. The functions for exporting graphics files are all located under the File program menu.

### ***Copy Graph***

Copy graph is located under the File program menu. It copies the active graph including titles, legends, slide bars and data descriptions to the clipboard in JPEG (.jpg) format using the default compression. The plot can then be inserted into other programs such as Word or PowerPoint for reports or presentation. A similar command is to use Alt-Print Screen to capture the active graph on to the clipboard as a Windows bitmap. In this case, you will have to use a graphics file editor to remove the window portion from around the graph.

## **Save To JPG**

Save To JPG is located under the File program menu. It saves the active graph including titles, legends, slide bars and data descriptions to a file in JPEG (.jpg) format. A Jpeg Quality pop-up window, as shown on the next page, prompts the user for the amount of compression to be used in saving the file. The compression shown in the figure is the default. The more compression that is used when saving a file in JPEG (.jpg) format, the smaller the size of the saved file, but also the poorer the resolution.

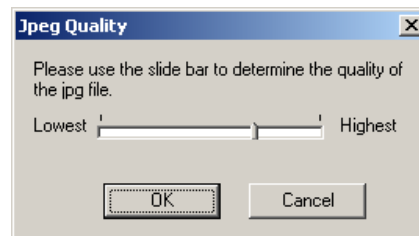

Jpeg Quality Window

## **Mail To**

Mail To is located under the File program menu. It opens the users default email program and attaches the active graph to a New Message. The Mail As pop-up window opens up as shown below and gives the user an option of attaching a file in the JPEG or Venable file format. Venable files are typically very small and are the most convenient format for emailing. However, the recipient needs The Venable System software or the Venable Reader to open this file type. If the JPEG format is selected, the user is given an option for the amount of compression to be used in the attached file. Again, the more compression that is used when saving a file in JPEG (.jpg) format, the smaller the size of the saved file, but also the poorer the resolution.

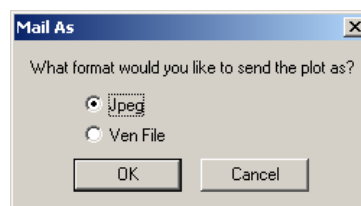

The Mail As Pop-up Window

## Importing Venable data into Excel

To import data into Excel you can directly paste any data copied on to the Clipboard from the Venable software directly into an Excel worksheet or you can open up any tab delimited text files that have been saved. When opening a delimited text file with Excel, the Text Import Wizard panel will open up. Choose delimited option and click on Finish to import the file.

## Importing Venable data into Mathcad

Data can be imported into Mathcad using three methods:

1. The user can go to the Mathcad Insert program menu, select the Component menu item, and then select Input Table. Type a variable name into the placeholder for the input table. Right click on the input table and select Import from the pop up menu. Browse for a data file saved by the Export to Matlab/Mathcad method or a file with the Venable text header removed and click Open. This method reads the data from the data file only once when the data is imported instead of each time the work sheet is calculated.
2. Data can also be imported by going to the Insert pull-down menu, selecting the Component menu item and then selecting File Read or Write. The File Read or Write Wizard should appear. Choose Read from a file, Text Files for the File Format, and browse for the data file and click on Finish. Type a variable name into the placeholder in the Read/Write component icon to which the data from the file will be assigned. Type the variable name and '=' to display the data in an input table. Mathcad re-reads the data from the file each time the work sheet is calculated.
3. Data can also be imported using the READPRN function. The proper syntax is to put the file path inside quotes inside the function parentheses as shown below:

```
M:= READPRN("C:\Program Files\Venable Inc\Venable System\mod.dat")
```

Type the variable name and '=' to display the data in an input table.

## Importing Venable data into Matlab

Matlab uses Matlab m-files Venload.m and Vendlmread.m created by Venable to import data into a Matlab array. These files are located in the C:\Program Files\Venable Inc\Venable 3120 System\ directory. The Venload.m and Vendlmread.m files must be placed in the Matlab path or current directory. See the topic on **Installing the Venable Matlab Files**. Once these files are placed in the Matlab path or current directory, the Venload function can be called from the Matlab command window or any user created m-file. A description of the functions and Matlab syntax is provided below.

Venload.m Sets C:\Program Files\Venable Inc\Venable 3120 System\ directory as the current directory, retrieves the tab-delimited text file name and calls the Vendlmread.m function. A tab-delimited text file with the file extension \*.dat is created using the Export To Matlab/Mathcad function under the File menu in the Venable System software.

Matlab Syntax: venload, loads file into the most recent answer array, ans.

Matlab Syntax: a = venload, loads file into array, a.

Vendlmread.m Parses and loads Venable frequency response data from a tab-delimited text file into a Matlab array.

## Importing Data into the Venable Software

The Venable software uses tab delimited ASCII text when exporting or importing data. Data has to be in this form to be imported into the Venable software.

### Venable Data Formats

Data can be imported using two different text formats. The Voltage or DOS format shows the 5-column raw data acquired from each analyzer channel. Data from the DOS versions of the Venable software can be imported and saved using the Voltage format as shown below.

Gain4.ven: Data 12:

\*Data from Synthesis / Circuit Analysis Menu

\*01:26PM Wednesday, December 04, 2002

\*Gain/Phase: Output Node=2, Input Node=1, Scale Factor=10

*Frequency (Hz)	Channel or Node	Voltage (Volts)	Voltage (dB)	Phase (Deg)
1	1	1	0	0
1	2	3.63637	11.2134	-0.1391
1.25893	1	1	0	0
1.25893	2	3.63637	11.2134	-0.1751

The Magnitude-Phase format is the 3-column text representation of a data set as plotted on a Venable software plot. The plotted data set consists of a channel ratio multiplied by a scale factor. When importing 3-column data the default scale factor will be unity and the default channel ratio set to 2/1. The channel ratio and scale factor settings for each plotted data set can be changed and are located in the Data Set Properties for each plot. An example of the 3-column format is shown below.

Gain4.ven: Data 12:

\*Data from Synthesis / Circuit Analysis Menu

\*01:26PM Wednesday, December 04, 2002

*Frequency (Hz)	Gain (dB)	Phase (Deg)
1	31.2134	-0.1391
1.25893	31.2134	-0.1751

Data is often saved as a tab delimited data file without the Venable text header. Data can be imported in this form also. See the example below:

1	31.2134	-0.1391
1.25893	31.2134	-0.1751

## Exporting tab-delimited text data from Excel

To export data from Excel you can select and copy data from cells on to the Clipboard and paste directly into a Venable software plot or the Frequency (AC) Data window in the Circuit Analysis Menu. You can also save the data into a tab-delimited text file with Excel. The data must be in the 3-column Magnitude-Phase format or 5-column Voltage format if it is to be successfully imported into the Venable software.

## Exporting tab-delimited text data from Mathcad

Data can be exported from Mathcad as a tab-delimited text file using three methods. The exported Mathcad data must be in the 3-column Magnitude-Phase format or 5-column Voltage format if it is to be successfully imported into the Venable software.

1. Type the data array variable name and '=' to display the data in an output table. Right click on the output table and select Export from the pop-up menu. Save the data to a tab-delimited text file with a \*.dat file extension. This method reads the data from the data file only once when the data is exported instead of each time the work sheet is calculated.
2. Data can also be exported by going to the Insert pull-down menu, selecting the Component menu item and then selecting File Read or Write. The File Read or Write Wizard should appear. Choose Write to a file, Tab-Delimited Text for the File Format, and browse for a data file name and directory to where the data is to be written and click on Finish. Type a variable name containing the data to be written to the file into the placeholder in the Read/Write component icon and hit Enter. The data will be written to the specified file. Mathcad re-writes the data to the file each time the work sheet is calculated.
3. Select all the data by clicking in the upper left corner of an input or output table. Use the Ctrl-C copy shortcut keys to copy the data to the clipboard. The data can be pasted directly into a Venable software plot, Excel or any text editor and saved.

Data can't be exported using the WRITEPRN function. This function uses space-delimiting and space-delimited text files can't be read by the Venable software:

## Exporting tab-delimited text data from Matlab

Matlab uses a Matlab m-file Vensave.m created by Venable to export data into a tab-delimited text file. This file is located in the C:\Program Files\Venable Inc\Venable 3120 System\ directory. The Vensave.m-file must be placed in the Matlab path or current directory. See the topic on **Installing the Venable Matlab Files**. Once this file is placed in the Matlab path or current directory, the Vensave function can be called from the Matlab command window or any user created m-file. A description of the function and Matlab syntax is provided on the next page.



Vensave.m Creates a tab-delimited text file from a Matlab array in a suitable format for importing into the Venable System software. The data must be in the 3-column Magnitude-Phase format or 5-column Voltage format if it is to be successfully saved to a file. The tab-delimited text file (\*.dat) can be imported into the Venable System software using the Import From Matlab function under the File menu.

Syntax: vensave(venarray), saves the array to a tab delimited text file.

Syntax: a = vensave(venarray), saves the array to a tab delimited text file.

a = 1 if the file is successfully saved.

a = 0 if the file is not saved.

### **Importing data into the Venable software using the Clipboard**

The Venable plot data including the data header can be exported to the clipboard as tab delimited ASCII text from Excel and Mathcad. There are two methods you can follow to import data into the Venable software from the clipboard.

1. Paste the tab delimited ASCII text data directly to plot from the clipboard. Data can be directly copied to the clipboard from Excel workbook or from Mathcad Input or Output tables.
2. Open the Circuit Analysis Menu, which is located in the Actions program menu. Left-click on the Frequency (AC) data tab. Right click for the Edit pull-down menu and select Paste or hit the Ctrl-V keys to paste the data into the text window. Left-click on the Import into Graph button to import data into the plot.

### **Importing data from Matlab/Mathcad into the Venable software**

The Import From Matlab/Mathcad function imports data files with a file extension of \*.dat saved by either Matlab or Mathcad into the Venable software plot. It will import data files saved with or without a data header. To use this function do the following:

1. Go to the File program menu and click on the Import From Matlab/Mathcad menu item. The File Open pop-up window will open up.
2. Browse for the tab-delimited text file containing the data to be imported and left-click on the Open button to import data into the plot.

## Using the Venable Circuit Analysis Menu to Import Data

The Frequency (AC) data window in the Circuit Analysis Menu imports data files with a file extension of \*.ac saved by Venable DOS software. It will also import tab delimited ASCII text data files (\*.dat and\*.txt) saved with or without a data header. To use this function do the following:

1. Open the Circuit Analysis Menu, which is located in the Actions program menu. Left-click on the Frequency (AC) data tab.
2. Left-click on the Open AC File button and the File Open pop-up window will open up. Browse for the tab-delimited text file containing the data to be imported and left-click on the Open button to import data into the text window. Left-click on the Import into Graph button to import data into the plot.

## Description and Uses of Accessories

Part number	Description	Function
200-001	Low frequency injection transformer	Couples and isolates AC source from circuit under test. Useful frequency range 1 Hz-10 kHz.
200-002	Medium frequency injection transformer	Couples and isolates AC source from circuit under test. Useful frequency range 10 Hz-100 kHz.
200-003	High frequency injection transformer	Couples and isolates AC source from circuit under test. Useful frequency range 100 Hz-1MHz.
200-004	Electronic injection transformer, DC-2.2 MHz	Couples and isolates AC source from circuit under test. Voltage on circuit must be $\pm 16$ volts or less.
200-005	Power supply for 200-004	Part of 200-004.
200-006	Clip-on injection transformer	Clips onto wire to inject signal without breaking circuit. Useful frequency range 1 kHz-15 MHz.
200-009	Balun to reject common mode noise	Connects in series with injection transformer to block high frequency common mode noise between circuit under test and measuring instrument.
200-000	Very low frequency injection transformer.	Used to measure the voltage loop in power factor correction circuits. Useful frequency range of 0.1 Hz to 1 kHz.
350-RLC	RLC Meter	Test fixture and software to automatically measure resistance, inductance, and capacitance of up to three components.
2249-C-60	BNC-BNC Cables	Connect FRA to injection transformer.
5187-C-60	BNC-Minigrabber Cables	Connect FRA directly to circuit under test.
3782-36-X	Banana-Minigrabber Cables	Connect injection transformer to circuit under test.
IOZ-50 IOZ-100	Input/Output Impedance Measurement Test Set. Also used for conducted susceptibility testing.	High power injection transformer for injecting up to 300 watts of AC power into lines carrying DC current of up to 50 or 100 amps depending on model selected.

## Calibration of Oscilloscope Probes for Flat Frequency Response

To read voltages higher than 100 VAC with the 3120 System or to minimize probe loading on a sensitive part of a circuit, you can use ordinary attenuating oscilloscope probes on the FRA inputs. These probes have a series resistor (9 mega ohms in the case of a 10:1 probe) paralleled by a variable capacitor. The inputs of the FRA are 1 mega ohm, just like an oscilloscope, so the probes work on the FRA just as they do on an oscilloscope. Also, as on an oscilloscope, the probes have to be “calibrated”. As with a scope, the term “calibration” means adjusting the variable capacitor that is in parallel with the series resistor so that the capacitive divider ratio is the same as the resistive divider ratio. The inputs of the FRA have a capacitance of about 50 pF, slightly more than most oscilloscopes, so the calibration for an oscilloscope will be slightly different than for an FRA. Here are the steps for calibrating a probe:

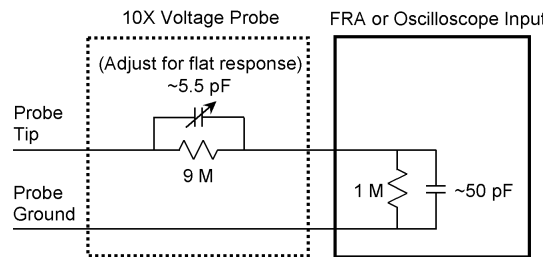

The objective is to treat the probe as a circuit you are trying to measure the frequency response of, then to adjust the variable capacitor so the attenuation at high frequency (determined by the ratio of the capacitors) matches the attenuation at low frequency (determined by the ratio of the resistors). The transition between low frequency and high frequency is typically in the range of 1-3 kHz. To do this, connect one of the BNC-Minigrabber cables provided to the FRA oscillator output. Connect the probe to the input channel you plan to use it on, then connect another BNC-Minigrabber cable to another input channel. If you plan to use more than one probe, calibrate them one at a time on the input channel they are to be used on.

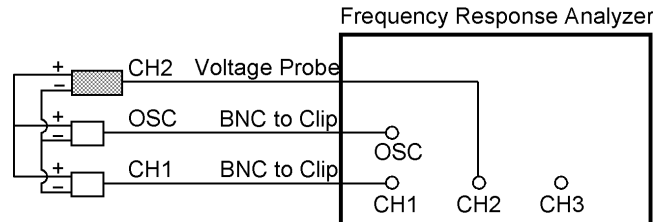

Connect all the grounds together and connect both the red Minigrabbers to the probe tip. For example purposes, we will assume that the probe is on channel 2 input and the Minigrabbers are on the oscillator output and channel 1 input.

Open the Venable System software and open a new Gain and Phase plot. Click the Analyzer Control icon to open the Analyzer Control menu. Set the sweep from 10 Hz to 100 kHz, log sweep at 10 steps /decade. The voltage is not critical.

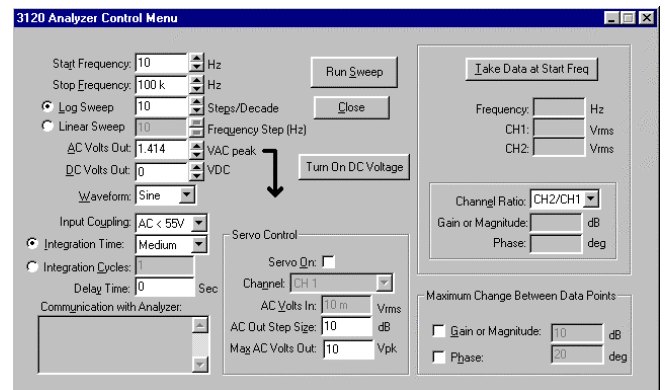

You may want to set it to a 1.414-volt sine wave when using the 3120 analyzer because the oscillator is specified in volts peak so the input channel will read 1 Vrms in the data box in the upper-right corner of the Analyzer Control window.

When the sweep parameters are set, click the “Take Data at Start Freq” button and let the analyzer take two or three readings. Check the data box to make sure everything is working. For example, if you used the same settings and channels as the example, the Frequency will be 10 Hz, Channel 1 will be 1 Vrms, and Channel 2 will be 0.1 Vrms if you are using a 10:1 probe. If everything is OK, click the “Run Sweep” button.

Again, you may want to minimize or move the Analyzer Control window so you can see the data in real time. If the probe is not calibrated correctly, there will be a small step in the attenuation at the frequency where the divider changes from a resistive divider to a capacitive divider, usually in the range of 1-3 kHz. More noticeable than the gain step will be a phase “bump” or “dip” at the same frequency. The phase will have a “bump” if the high frequency gain is higher and a “dip” if the high frequency gain is lower.

When the sweep is complete, note the frequency of the peak or valley of the phase curve. You can add a slide bar to make it easier to measure the frequency.

Open or maximize the Analyzer Control window and set the start frequency to the frequency of the peak or valley of the bump or dip in phase. Click the “Take Data at Start Freq” button and note the Phase reading in the data box in the right-center part of the Analyzer Control window. It should be the same as the peak or valley phase reading on the gain-phase graph.

Turn the adjustment screw on the probe to set the phase as close to zero as possible. Zeroing the phase at the corner frequency automatically flattens the gain curve. If you want, you can do another sweep from 10 Hz to 100 kHz to check your handiwork.

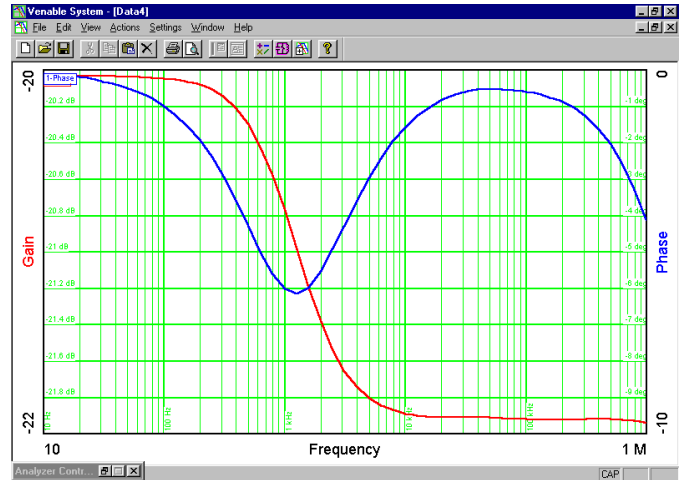

Uncalibrated probe

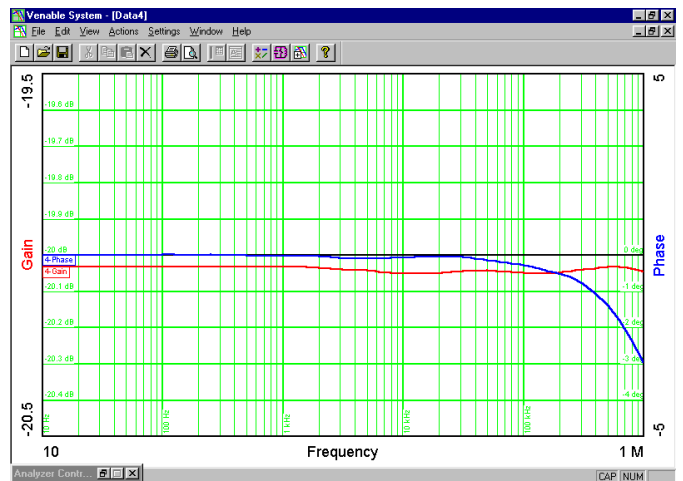

Transfer function of calibrated probe. The gain and phase deviations at 1 kHz are minimized. Note the narrow gain and phase ranges of the graph.

## Measurement of the Loops in a Multi-Loop Power Supply

By multi-loop, we mean there are several paths for the signal to take as it goes around the circuit, essentially creating a number of different loops which have some parts in common and other parts as separate parallel paths. This is common in power supplies that use a TL431 and optocoupler to cross the isolation barrier, in power supplies that use feedback from more than one output, and in magamp post-regulator circuits.

This is not to be confused with the term “multi-loop control” coined by Virginia Polytechnic Institute (VPI) to describe current-mode control. There are a number of viewpoints about the significance of the current loop, exemplified by the controversy between VPI and the California Institute of Technology (Cal Tech) on this subject. The view here at Venable Industries is that the current loop simply forms a transconductance gain block in the overall loop and can be treated as one more gain block in series with a number of other gain blocks in the overall loop.

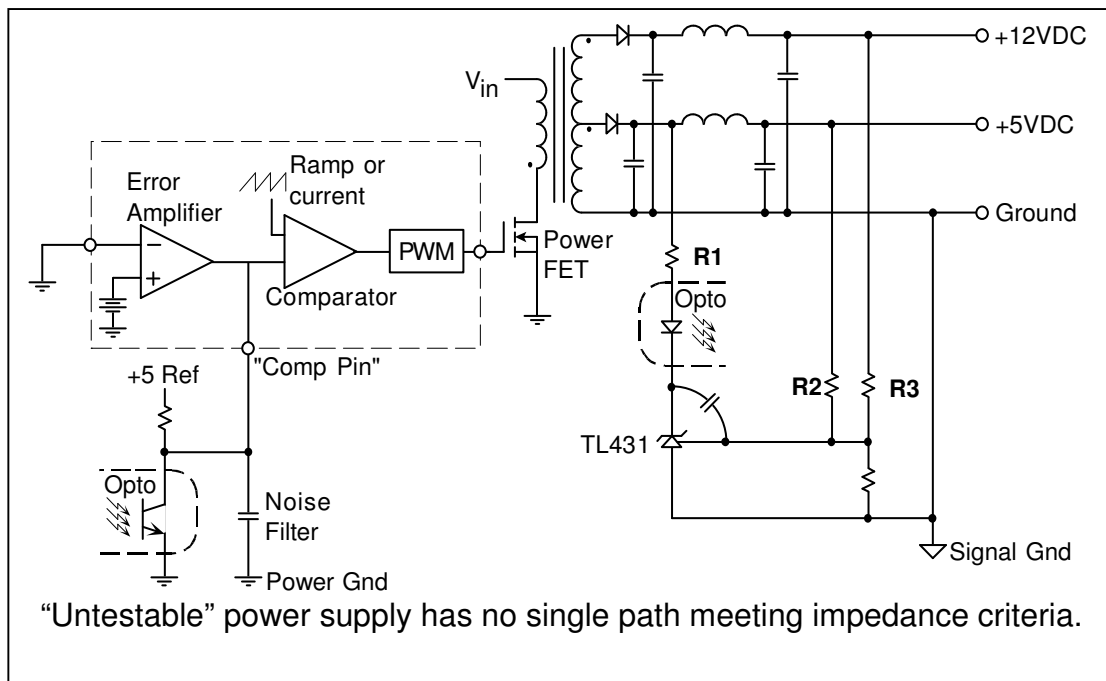

The above figure shows an “unstable” power supply. Unfortunately, this topology is not that unusual. There is no single path that meets the criteria of coming from a low impedance and driving a high impedance. The path into the “Comp Pin” of the PWM chip might qualify, but it is hard to be certain because the source impedance is high and the input impedance of the “Comp Pin” is unspecified. In addition, this point is usually very noise sensitive.

On the secondary side there are three paths that meet the impedance criteria, but all three of these paths are in parallel. There are two paths that most people recognize: the 5 V loop through R2 and the 12 V loop through R3. It is common to take part of the feedback from the 5 volts and part from the 12 volts so that instead of having one output

be perfectly regulated and the other vary 10% or so with line and load changes, both outputs vary by about 5%. The path that is not widely recognized is the path through R1. We call this the “fast loop” because it is the loop that dominates at high frequency. This path originates because the gate (control pin) of the TL431 is a virtual ground, and the capacitor connected from there to the cathode makes the cathode a virtual ground also at high frequency. Any AC voltage on the 5 V output modulates the current in the optocoupler diode directly through R1 by virtue of the fact that the branch ties between the 5 V output and a virtual ground. This direct modulation of the current in the optocoupler diode is much faster than the signals through R2 and R3, especially in the presence of the capacitor from cathode to gate.

In this topology example, there is a second L-C filter after the power stage to further reduce switching ripple at the output. This is also common, but the phase shift through the second L-C filter makes it difficult if not impossible to cross the loop over at a high bandwidth while sensing directly at the output of the power supply. Some designers solve this problem by connecting the “fast loop” through R1 to the junction between the power stage and the second L-C filter as shown in the example, avoiding the excess phase shift in the “fast loop”. The “slow loop” through R2 and R3 provides good DC regulation. The AC loop response does not compensate for the second-stage L-C filter, but the fact that the loop bandwidth is much higher than would otherwise be possible means that the overall performance may actually be improved over a slower loop with the “fast” path tied to the output after the second-stage filter.

The problem with this topology is that there is no common point between the fast and slow loops as there is in the example given earlier in the basic part of this manual. If there was, at least the fast and slow 5 V loops could be combined into a single path. In this case, all three of the loops are separate. We solve this problem by measuring the loops separately and then combining them mathematically using the “Do Math on Data” window. One of the options in this window is called “Double to Single Loop”. Parallel loops can be combined mathematically by the formula:

$$\text{LOOPGAIN} = \frac{\text{GAIN1} + \text{GAIN2} - 2 \times \text{GAIN1} \times \text{GAIN2}}{1 - \text{GAIN1} \times \text{GAIN2}}$$

This is the formula implemented in the “Double to Single Loop” function of the “Do Math on Data” window. When there are more than two loops, as in this case, the loops can be combined in pairs and the result combined with the additional loops one at a time.

When the true loop gain is high, the product of GAIN1 x GAIN2 will be close to 1 and the denominator of the equation will be small. The slow loop and fast loop will both cross the 0 dB gain axis at approximately the same frequency. With this formula there is the problem of a small difference between two similar numbers since at low frequency the term GAIN1 x GAIN2 is very close to +1. At low frequency the denominator of the equation is small since it is the difference between +1 and another number very close to +1. This causes some inaccuracy in the gain measurement when the gain is very high, but near loop crossover the gain is small and the small difference of large numbers

problem becomes insignificant. You can judge for yourself the effect from the examples below which are real test data from a production computer power supply.

The figure to the right is the “slow” loop measured at the top of R2. This is actual test data from a 5 V power supply using a TL431 and optocoupler in the feedback path. The loop crosses over about 60 Hz with over 90 degrees of phase margin.

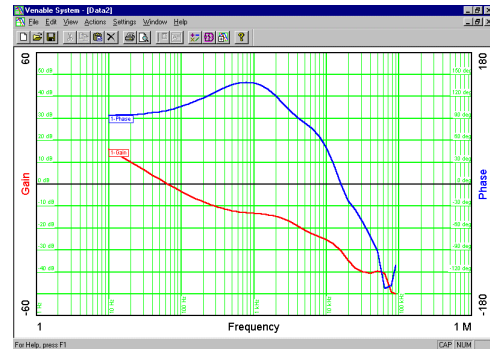

The figure to the right is the “fast” loop measured at the top of R1. This is also actual test data from the same 5 V power supply with the same TL431 and optocoupler in the feedback loop. There is no gain in this loop at low frequency because all the low frequency gain comes from the “slow” loop. This loop has a bandwidth of 6 kHz with about 90 degrees of phase margin.



This is the “Do Math on Data” window. To use this window, first display both the “slow” loop and the “fast” loop on the same graph. If you take the data on one loop and then the other, they will both be on the same graph. If not, you can do a cut and paste.

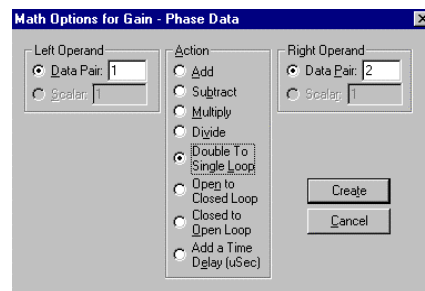

This is a graph with both the “slow” and “fast” loops displayed, together with the results from the Double to Single Loop conversion. The “slow” loop was selected as Data Set 1 and the “fast” loop was selected as Data Set 2. When the “Create” button is clicked, the result of the calculation is displayed as the loop resulting from the parallel combination of the “slow” and “fast” loops.

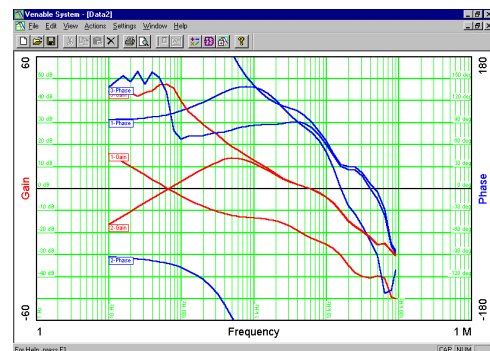



The graph at right is the total 5 V loop displayed as a separate graph by copying the Data Set from the previous graph and pasting it onto a new graph. This loop crosses over at about 6 kHz with about 85 degrees of phase margin. You can read the exact values by adding a slide bar to the Data Set and moving the slide bar to the unity gain frequency of the loop. Once this loop is calculated, the same process can be repeated with the “slow” 12 V loop.

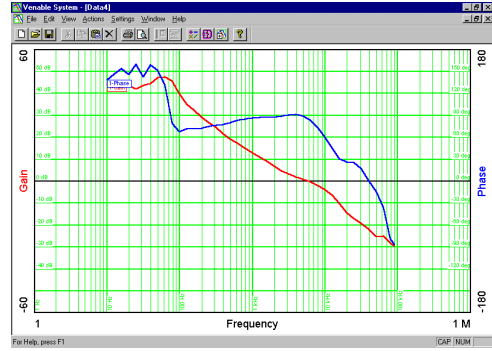

## Measurement of the Pieces of a Loop

One of the most powerful techniques for analyzing and evaluating a circuit is to model it and then compare the model result with test results. Usually they will not match the first time. If a circuit is complex, like the one below, the loop is made up of many pieces. When the model and test results do not match, it is difficult to tell exactly which piece of the loop is causing the problem. The way around this dilemma is to test each piece of the loop separately, then compare test data from each piece of the circuit to the model results for that equivalent piece. If the pieces match, the model is probably accurate for that particular piece. If the pieces do not match, then you know which part of the model needs to be improved upon. The circuit is never wrong, it does what it does. If the model does not match, it is the model that needs fixing. It is possible that the circuit is not designed or built correctly and both the circuit and the model have to be changed, but an essential first step is to have the model results match the test data.

The loop in the example to the right is broken into 6 pieces. What you define as a piece of the loop is arbitrary, but it is helpful to break it up into the smallest functional blocks that can be conveniently measured and analyzed. One thing not shown on the above diagram is the signal injection point. A typical injection point would be in the trace where the filtered output voltage ties to R5 and R7, but you can inject anywhere. The FRA inputs are connected to the input and output of the gain block being tested.

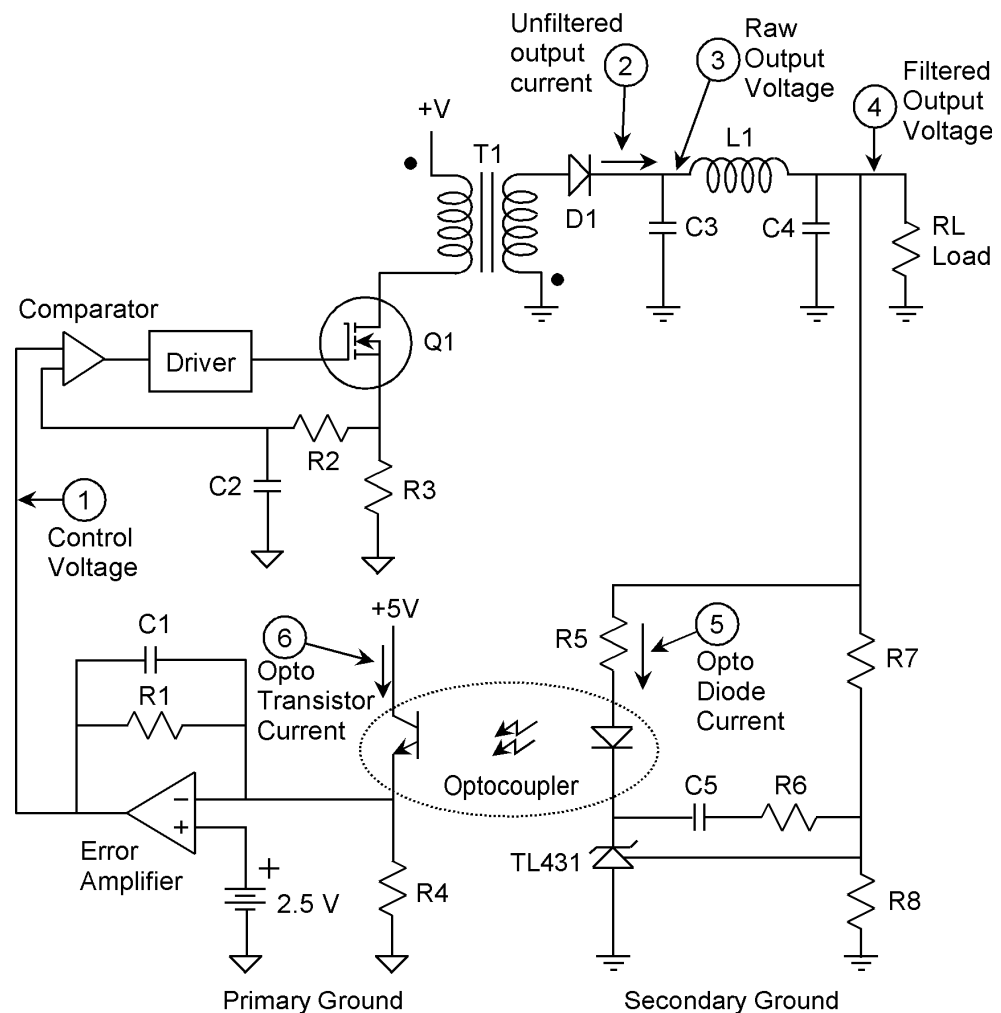

The six pieces of the loop are:

- 1) The transconductance of the power stage from control voltage in to unfiltered DC output current. The input is the compensation pin of the PWM integrated circuit and the output is the current in the rectifier diode measured with a current probe.
- 2) The unfiltered DC output current to raw output voltage. The input is the current in the rectifier diode measured with a current probe and the output is the voltage across the first set of filter capacitors.
- 3) The raw output voltage to filtered output voltage. The input is the voltage across the first set of filter capacitors and the output is the DC output voltage of the power supply.
- 4) The filtered output voltage to current in the optocoupler diode. The input is the DC output voltage of the power supply and the output is the current in the optocoupler diode. This current can be measured with a current probe or by measuring the voltage directly across R5, taking advantage of the fact that the input channel returns of the Venable Model 3120 analyzer float.
- 5) Current in the optocoupler diode to current in the optocoupler transistor. This is called the current transfer ratio, CTR. It is constant at low frequency but rolls off at high frequency. The input is the current in the optocoupler diode, measured as described in block 4 above. The output is the current in the optocoupler transistor. The output measurement requires a current probe, and most likely cutting a circuit trace. It is not strictly necessary to measure this particular gain block, since all the AC current through the transistor has to flow through the parallel combination of R1 and C1. The inverting input of the error amplifier is a virtual ground and no AC current flows through R4. The reason you might want to make this particular measurement is to be able to separate the parasitics of the optocoupler from the parasitics of the error amplifier so you can make your model more accurate.
- 6) Current in the optocoupler transistor to control voltage out of the error amplifier. The final block has the current in the optocoupler transistor as the input and the control voltage (output of the error amplifier) as the output. This gain should be just the optocoupler transistor current times the parallel impedance of R1 and C1, but the gain-bandwidth product of the error amplifier is often an important parasitic affecting the gain of this particular block.

Some of these pieces require the use of a current probe. The output of a current probe is not 1 volt per amp unless the current probe is set to the particular range that gives this scale factor. You can use the "Scale Factor" provision of Data Set Properties to scale the data for the particular current probe gain setting so that the output is always 1 amp per volt.

## Measurement of the Impedance of Components versus Frequency

There are two ways to measure impedance of components. We offer an RLC measurement package that has a test fixture and special software to correct for measurement fixture parasitics in real time as the measurements are being taken. This is the first and easiest way to measure impedance of components.

The second way, the method described here, does not require any additional hardware or software except a single resistor. Although, you can use our RLC test fixture if you have one. It has the same connections as shown in the figure below. The ability to measure and display impedance is a built-in feature of the Venable software package. This includes the ability to measure parasitics of test fixtures. The Do Math on Data window can be used to correct for test fixture parasitics. This procedure is not difficult but it is not automatic the way it is in the RLC measurement package software.

Impedance is voltage divided by current. We use the oscillator output of the FRA as a signal source. We connect the oscillator to the component under test, usually through a series resistor. You can measure the current with a current probe, but it is usually easier to take advantage of the floating inputs of the analyzer and measure current by measuring the voltage across the resistor in series with the component under test. There is about 200 pF of stray capacitance from return to chassis and about 50 pF of capacitance from input to return of the analyzer inputs. For this reason, we usually connect the current measuring channel (CH1) “backward”, so the return is connected to the oscillator output as shown in the figure. This minimizes the parasitic capacitance across the component under test.

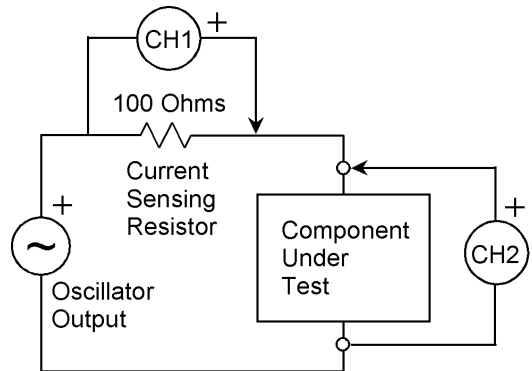

Let's measure the impedance versus frequency of an electrolytic capacitor as an example. The first thing to do is find a good resistor to sense the current. It should be non-inductive, such as a film resistor. The value is not critical but a value around 100 ohms will give a good balance between the impedance being tested and the open circuit and short circuit parasitic impedances. Although the particular value is not critical, it *is* important to know the absolute value of the current measuring resistor. You should measure the value with a good ohmmeter before you start or use a resistor with a tight tolerance.

Connect the oscillator output, channel 1 input, and channel 2 input as shown in the figure above or connect the RLC test fixture to the analyzer. Open the Venable System software and click on the Analyzer Control icon to open the Analyzer Control window. Adjust the settings to match the

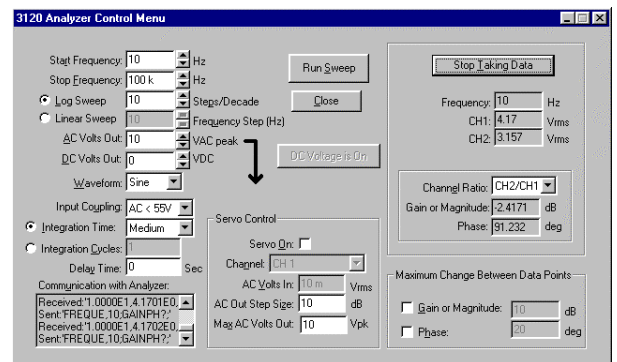

sample screen on the previous page. We used the maximum output voltage (10 V peak for the Model3120) to get the best accuracy and Medium integration time for speed. Before starting the sweep, make sure the graph screen displayed is a blank impedance plot. You can open a new one when you click the New Graph icon or click File-New and then click on Impedance and Phase plot. Then, after adjusting the Analyzer Control settings, click the “Take Data at Start Freq.” button. When the analyzer has taken a few data points, click the “Run Sweep” button.

A window will pop up displaying the Output Node, Input Node, and Scale Factor. If you made the same connections as the test setup schematic on the previous page or are using the RLC test fixture, Output Node will be 2, Input Node will be 1 (both default values), but the Scale Factor has to be changed to match the value of the current sensing resistor. In this case, with the current measuring channel connected “backward”, the polarity of CH1 will be “backward” also. You correct this by entering the current sense resistor value as negative. If you used 100 ohms to measure the current, enter the Scale Factor as –100 in the Data Set Properties dialog box as shown above. If you are using a current probe, the Scale Factor is the Volts/Division divided by the Amps/Division of the current probe amplifier. When you have changed the Scale Factor to match the current sensing device and the circuit connection, click OK and the sweep will start. You may want to move or minimize the Analyzer Control window so you can see the data being taken in real time.

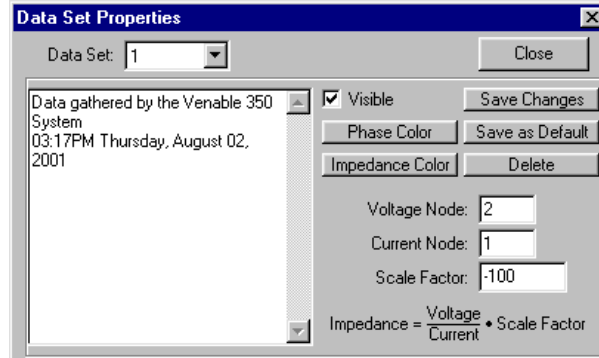

The graph does not automatically autoscale except for sweeping beyond the current graph frequency limit. When the sweep is complete, you can change the scale manually by double-clicking on any open area of the graph, entering the desired minimum and maximum values, and then clicking OK. You can autoscale by clicking the “Autoscale” box and then clicking OK. In the example shown, we were testing an aluminum

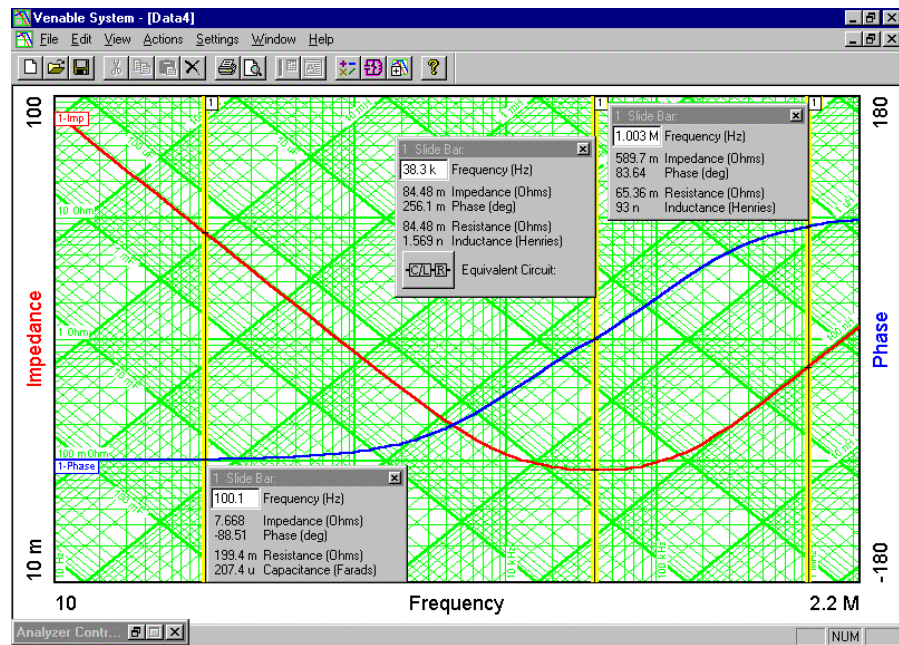

electrolytic capacitor with a rated voltage of 35 VDC and a nominal capacitance value of 200  $\mu\text{F}$ . We added slide bars to show the capacitance at 100 Hz (207.4  $\mu\text{F}$ ), the ESR when it is purely resistive (84.48 milliohms), and the inductance at 1 MHz (93 nH).

The only problem with the graph on the preceding page is that the parasitics of the test setup are not taken into account and may be significant at low or high impedance levels. To check on this, let's measure the parasitics. To do this, simply make the same measurement as before, except do it with the Component Under Test being first an open circuit and then a short circuit. Here are the results of those two measurements. For clarity, the plot type is impedance only.

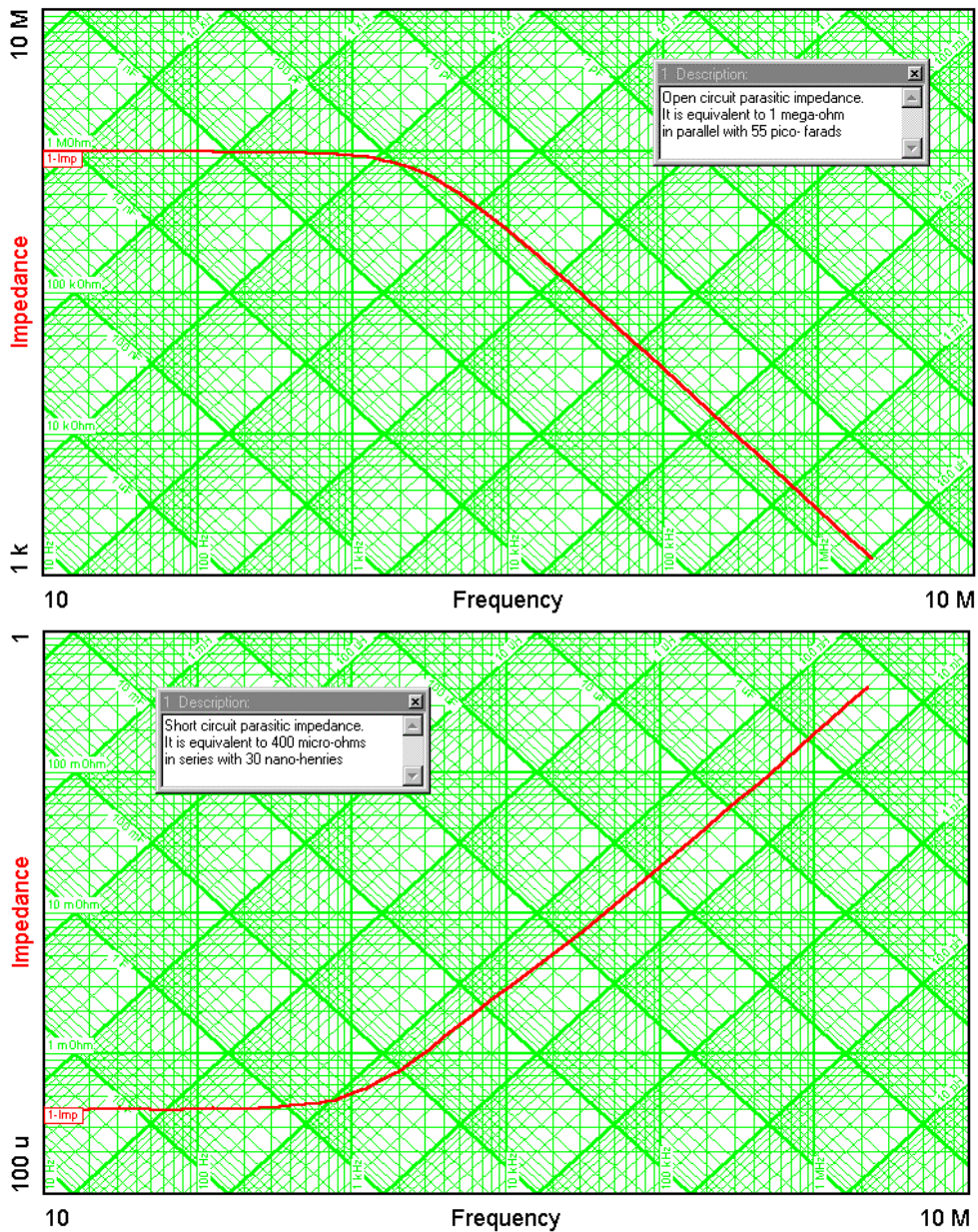



The graph below shows the result of using “Do Math on Data” to subtract the parasitic short circuit impedance from the capacitor impedance test data. The impedance is too far below the open circuit impedance to require compensation for open circuit parasitics. The true inductance of the capacitor can be seen in the text box near the slide bar to be 59.21 nH instead of the 93 nH we measured without correcting for short circuit parasitic impedance.

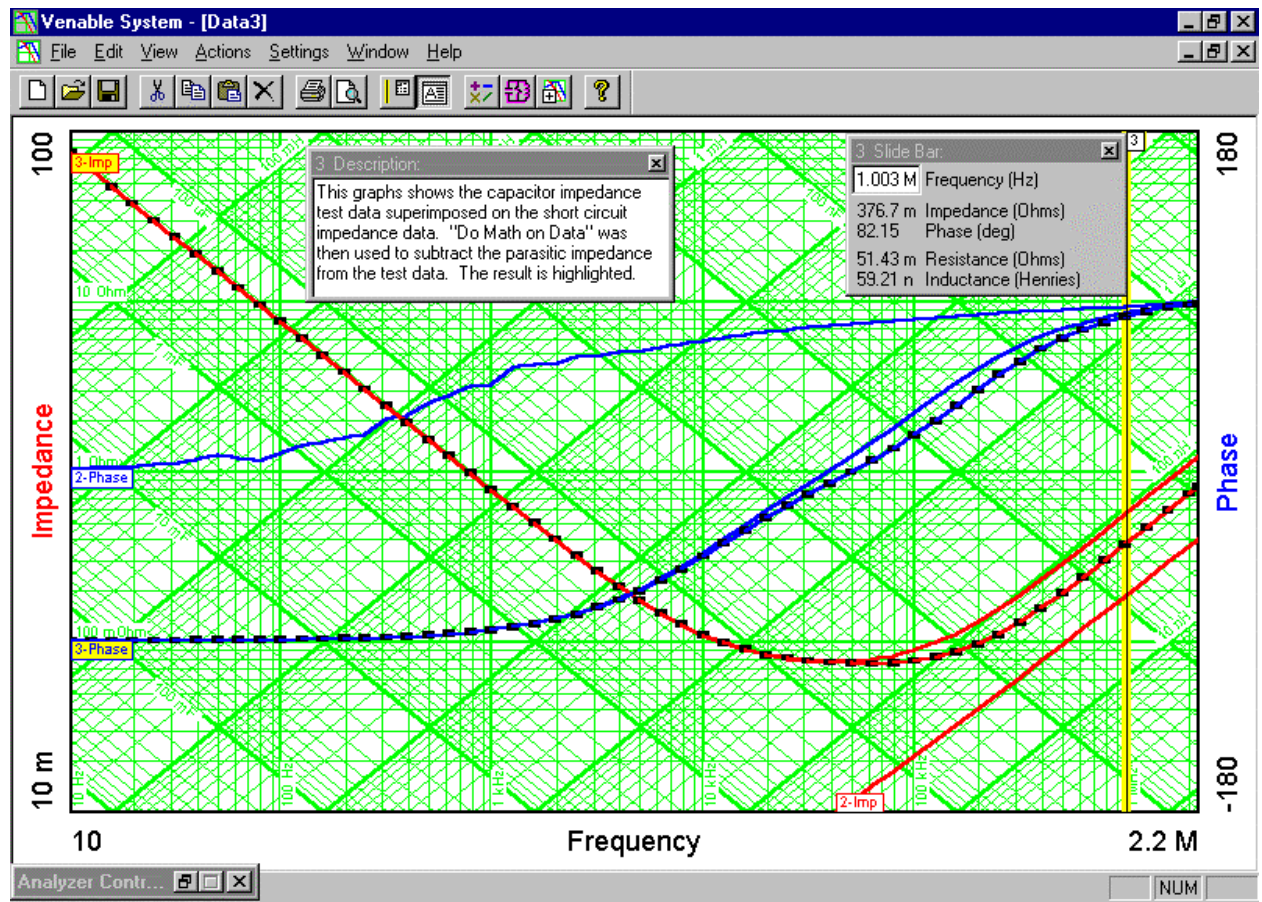
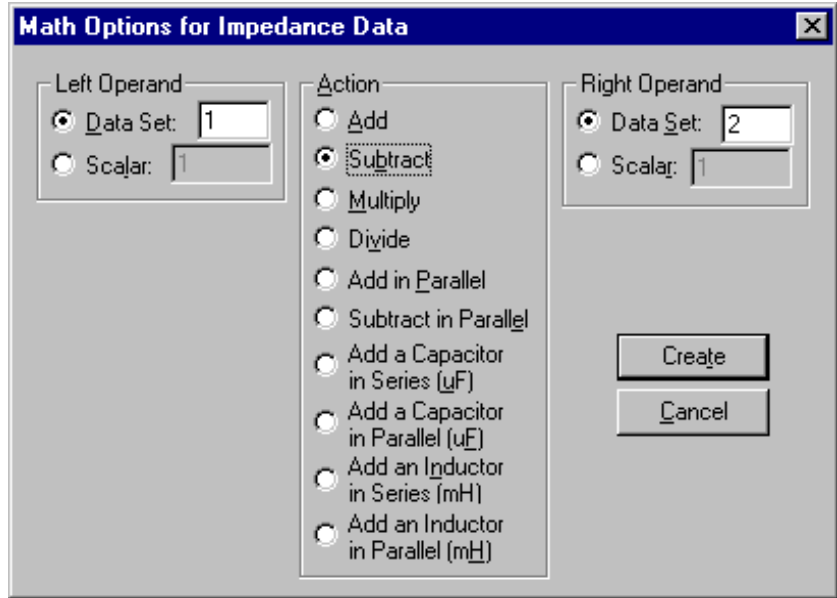

The example on the previous pages was for measuring a low impedance and correcting for short circuit parasitics by subtracting the short circuit impedance from the test data. The same concept can be used for measuring high impedances and correcting for open circuit parasitics, except it is a little trickier because the open circuit parasitics are in parallel with the test data instead of in series.

The best way to illustrate the difference is with an example. Let's say we want to measure a 10 pF capacitor. This is a lot smaller than the parasitic capacitance of approximately 60 pF for a 3120 Analyzer and the impedance of a 10 pF capacitor is greater than the parasitic resistance of 1 mega ohm for all frequencies below 16 kHz. To do the test, first connect the 10 pF capacitor as the "Component Under Test" in the test setup on page 36 and run a sweep as before choosing "Impedance and Phase" as the plot type.

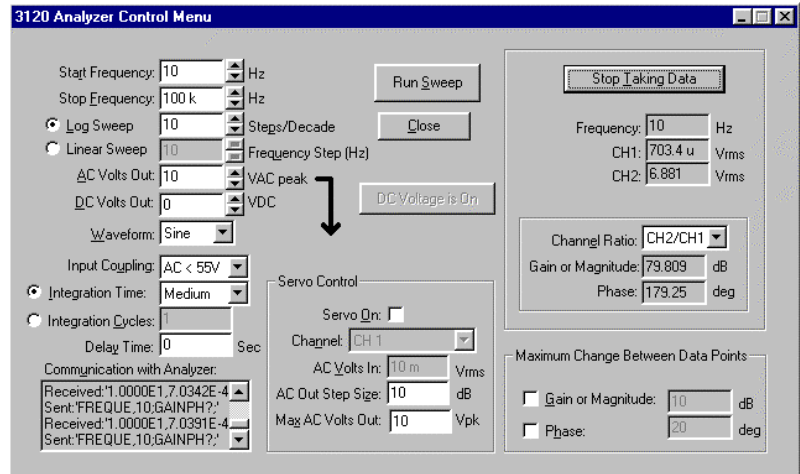

The Analyzer Control window is to the right and the resulting plot with the scales changed to accommodate the data is shown below. Choose "Impedance and Phase" as the graph type and choose Voltage Node = 2, Current Node = 1, and Scale Factor = -100 if you are using a 100 ohm resistor to measure the current and the connection is the same as the figure on page 47 or if you are using the RLC test fixture.

The graph to the right shows the impedance versus frequency plot of the 10 pF capacitor together with the parallel parasitic resistive and capacitive admittance. So far, it just looks like 1 mega ohm in parallel with about 70 pF, but we would like to look at the 10 pF capacitor by itself, not in parallel with all those parasitic elements. To do that, we need to run another sweep and then use "Do Math on Data" to fix the plot.

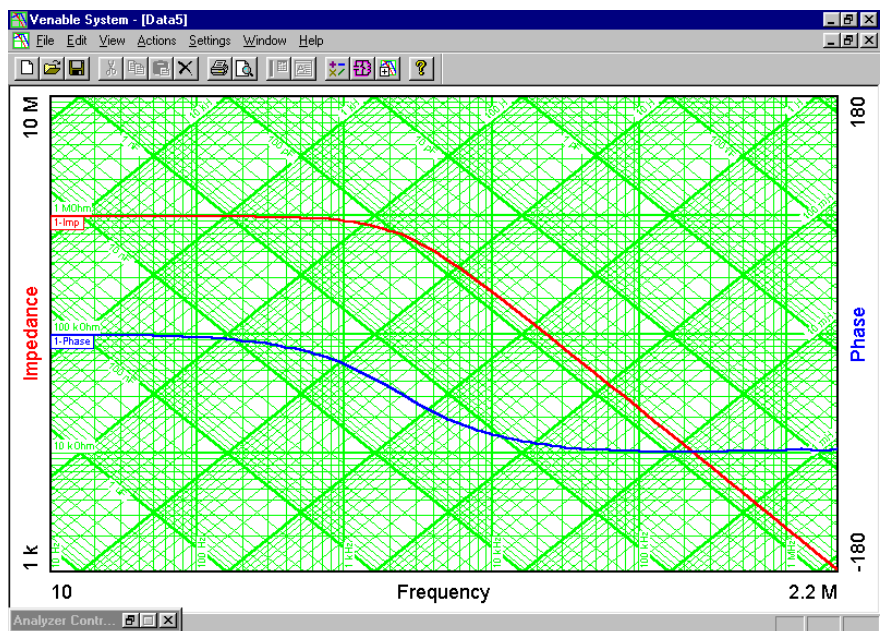



Disconnect the 10 pF capacitor from the test setup but leave the 100 ohm resistor and leave the oscillator and both voltmeters connected as before. Run a second sweep with nothing connected except the voltmeters. This is the open circuit impedance plot.

There will not be much difference between the two. The graph to the right shows both sets of data with the open circuit parasitic data highlighted (selected).

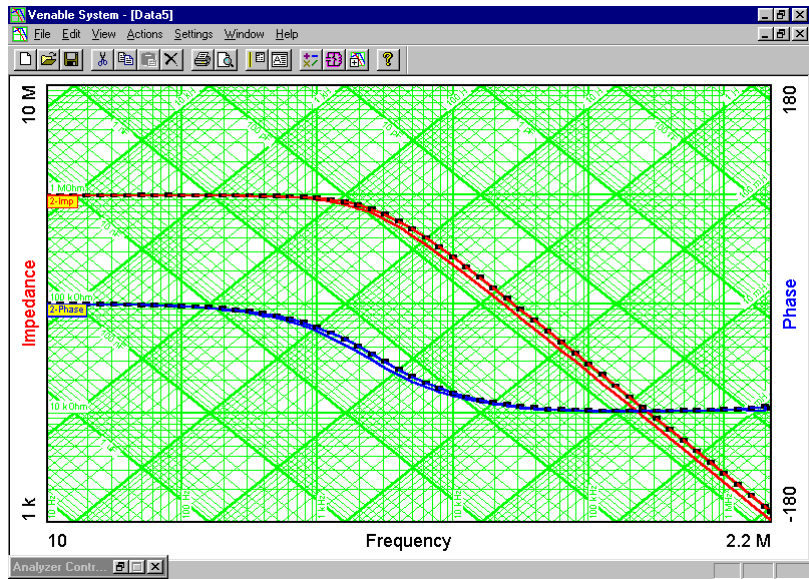

Now comes the tricky part. What you want to do is subtract the *admittance* of the open circuit parasitics from the *admittance* of the test data (which includes the impedance of the component

under test in parallel with the parasitic open circuit impedance). We have a feature in “Do Math on Data” called “Subtract in Parallel”. This will put the negative of the parasitic impedance in parallel with the test data, effectively canceling out the open circuit parasitic impedance and yielding only the impedance of the component under test.

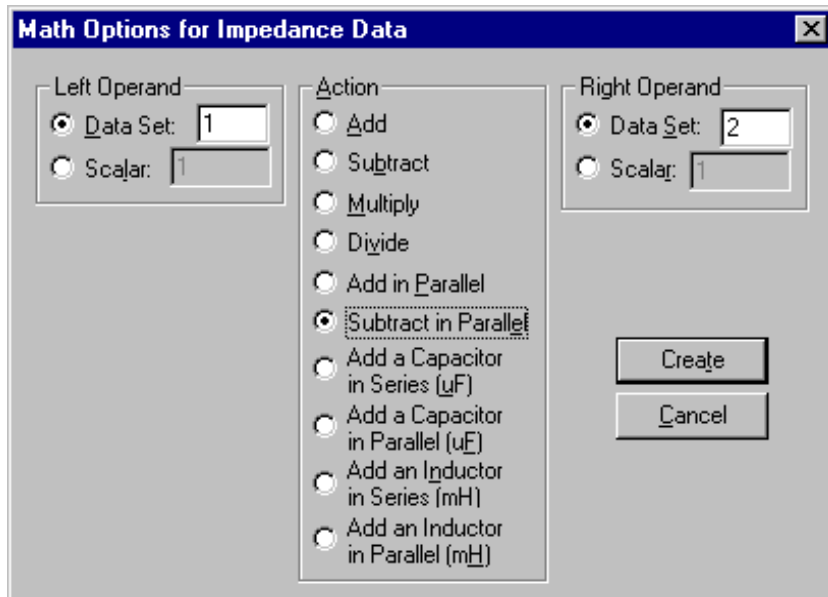

The plot on the upper right shows the results of the step on the previous page. The highlighted curve is the result of doing a "Subtract in Parallel" of the test data with from the parasitic data.

The graph below is the final impedance versus frequency graph of the 10 pF capacitor. The impedance data is accurate up to about 100 mega ohms. Beyond that, the data is noisy because the parasitic resistance is only 1 mega ohm. At the upper left corner of the graph we are trying to resolve the difference between 1 mega ohm and 1 giga ohm in parallel with 1 mega ohm, and understandably the result has a little variance because we are approaching the limits of measurement resolution.

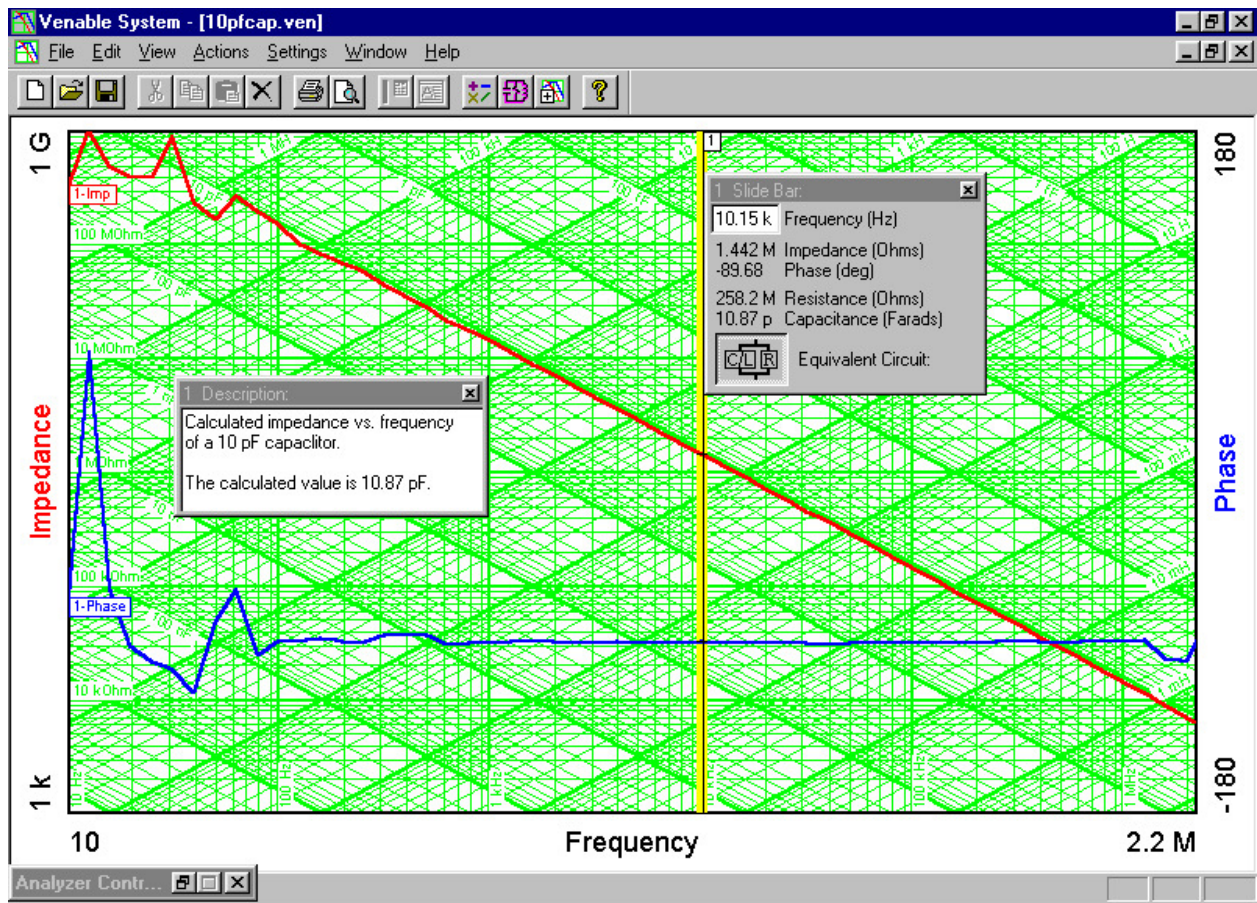
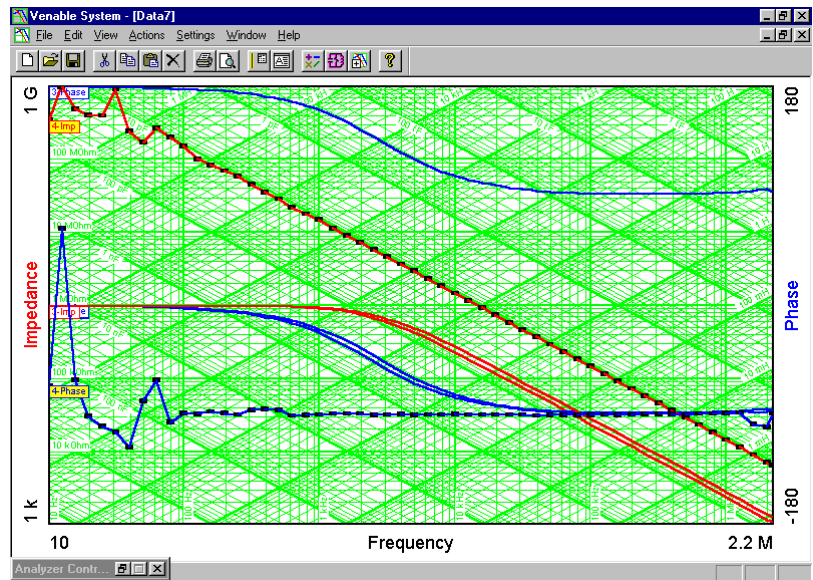

## Measurement of the Input and Output Impedance of Power Supplies

With the Input/Output Impedance Test Set option of the Venable Instruments System, you can measure input and output impedance of any power supply (or almost anything else for that matter). The Input/Output Impedance Test Set consists of a high-power 4-quadrant amplifier and power injection transformer. The injection transformer is capable of handling large amounts of DC current while still coupling an AC signal into the circuit. The standard power amplifier is rated 300 watts, and higher power ratings are available on special request. The injection transformer is rated 50 or 100 amps DC depending on model. Because the power amplifier is 4-quadrant, this system will also work for making measurements with an AC power source instead of DC. Since AC load current is transformed by the injection transformer and has to flow through the power amplifier, check with us here at Venable Instruments before making high power AC measurements to make sure the power amplifier is not overloaded and damaged. DC measurements are safe up to the rated current of the injection transformer.

The test setup at the right shows a general purpose setup for measuring impedance. If the “Source” is truly a source and the “Load” is the Unit Under Test, this setup will measure input impedance of the Unit Under Test. As with component measurements, impedance is voltage divided by current. In the test setup shown, source output impedance is CH3/CH1 and load input impedance is CH2/CH1

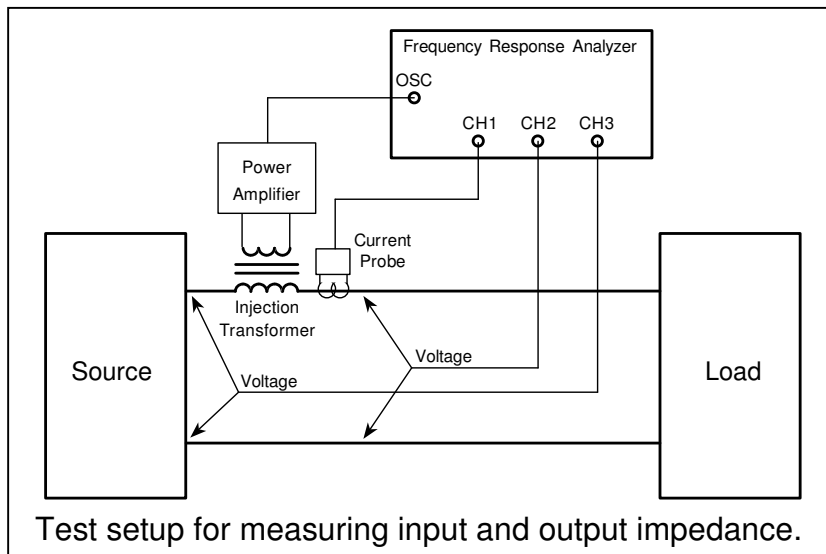

noting that there may also have to be a scale factor if the output of the current probe amplifier is not 1 volt per amp. If the “Load” is the Unit Under Test, CH2/CH1 is the input impedance of the Unit Under Test.

If the “Source” is the Unit Under Test and the “Load” is an actual or simulated load, this test setup will measure the output impedance of the Unit Under Test. CH3/CH1 is the output impedance of the Unit Under Test. If your system does not have a channel 3, such as the Venable 3120, then you must move CH2 to the source side of the injection transformer to measure the output impedance of the Unit Under Test.

Current probes are directional. If the arrow on the current probe is pointing toward the load, then the measured impedance of the load will be the correct polarity. The scale factor of the data set will be the effective resistance of the current probe, which is the rated volts per division of the current probe amplifier output (usually 0.01 volts per

division) divided by the amps per division setting of the current probe amplifier. For measuring the output impedance of the source, if the arrow on the current probe is pointing toward the load (away from the source) then the scale factor will be the negative of the value calculated above for the load input impedance data set. It is important to pay attention to the direction of the current probe arrow, especially if you do not have a feel for the expected phase of the test result readings.

Impedance measurements are a lot trickier than they look. The hardest part is getting the current probe set up properly. The second hardest part is making sure the drive levels are correct and nothing is being underdriven or overdriven. The third hardest part is getting the scale factor and polarity correct.

Let's start with the current probe. If you want good performance at low frequency, choose a DC current probe such as the Tektronix AM503S System. The current probe is not part of the Venable System or the Input/Output Impedance Test Set. It must be purchased separately if you do not already have one. Models are available in 20, 100, and 500 amp versions. Try to use one matched as closely as possible to the current you plan to measure. Trying to measure a few milliamps with a 100 or 500 amp current probe will not give very satisfactory results. The next thing to remember is that the Tektronix current probe amplifier is made to work into a 50 ohm load. That means you need to put a coaxial 50 ohm termination on each input of the FRA that is measuring current. The termination goes on the frequency response analyzer end of the BNC cable, not the current probe amplifier end. Make sure the termination is really 50 ohms by checking it with a good ohmmeter. You would be amazed how many 50 ohm terminations are "burned up" from connecting them to high-power sources. The accuracy of the impedance measurement is dependent on the accuracy of the 50 ohm termination. Failure to properly terminate the current probe is a common source of error in impedance measurements. Once you have chosen a current probe of the correct current rating and properly terminated it, the next area of concern is the range setting of the current probe amplifier. The Tektronix current probe amplifier has a dynamic range of about  $\pm 10$  divisions. In other words, if you set the current probe amplifier to 1 amp per division, it will read accurately up to about  $\pm 10$  amps. In general, the measurements we are making are on DC power lines. We are superimposing a small amount of AC voltage in series with the DC output voltage of the source in order to make a small AC deviation in the DC current being drawn or supplied. The current probe amplifier range should be set so the DC current represents a large portion of the dynamic range but does not exceed the dynamic range. For best accuracy, choose a range setting where the DC current being sensed represents between 3 and 8 divisions. For example, if the DC current is 3 amperes, the current probe amplifier setting can be 1 amp per division (3 divisions) or 0.5 amps per division (6 divisions). Either setting will work and give good sensitivity without saturating the current probe amplifier.

The next critical adjustment of a current probe amplifier is DC balance. The newer current probe amplifiers are self-balancing, but older ones need to be adjusted so they output 0 volts DC when there is no current flowing through the probe. A small amount of DC error will not cause a problem since the FRA rejects DC, but if there is a large

balance error it can affect the dynamic range of the amplifier and cause it to saturate with less than 10 divisions of deflection. Current probes get “gaussed”, which means that they have some residual flux in the core of the transformer used to sense current. The DC balance adjustment corrects for this residual flux. Current probe amplifiers have a “Degauss” button, which drives the internal transformer with a large amplitude but exponentially decreasing AC excitation with the objective of minimizing the residual flux in the transformer. After you “degauss” the current probe, you will have to readjust the DC balance setting. The problem is that when you make another measurement, the DC current flowing through the probe “gausses” the transformer again and it immediately needs to be readjusted for DC balance. Our recommendation is to not degauss the probe because you will only make it difficult to adjust the DC balance again once you start taking measurements. One highly recommended step is to connect an oscilloscope in parallel with the FRA input (after the 50 ohm termination) so you can see the level of DC offset, the amount of deflection caused by the DC current, and the amount of AC deviation superimposed on the DC current.

The final detail of using a current probe is to calculate the effective resistance of the probe. If you used a resistor of value  $R$  to measure current, you would get  $R$  volts across the resistor for every amp through it. The current probe has an effective resistance, which is the number of volts out of the current probe amplifier for every amp through the current probe. The Tektronix AM503 series of current probe amplifiers have a fixed output of 0.01 volts for a unit of current equal to the range setting. The current probe amplifier output is 0.01 volts per division and the range setting is given in amps per division so the effective resistance of the current probe is 0.01 divided by the range setting. If the amplifier is set to 10 milliamps (0.01 amps) per division, then the effective resistance is 1 ohm. One common error in making impedance measurements is to leave the current probe amplifier set to 10 milliamps per division no matter what current is being measured. This simplifies the math, since there is no need to use the Scale Factor provision of the testing and plotting software. It also means that often the current probe will be operated far from its optimum range, sometimes even in the saturation region where the output is no longer linearly proportional to the input. Failure to choose the proper range is another common source of error in impedance measurements. That about covers the common mistakes people make in the use of current probes.

Now let's go to the subject of drive levels. There are two variables in setting the drive level. One is the level of the Oscillator Output of the FRA; the other is the gain setting of the power amplifier. Since the amplifier output is the product of these two gain settings, there are an infinite number of gain setting possibilities for any given output level. The simplest way to set the level is to use one of the gain variables to set the injection transformer output level to the desired level at an intermediate frequency such as 1 kHz and then leave the gain settings alone during the sweep. An effective way to do this adjustment is to set the FRA Oscillator Output to a reasonable level like 1 volt and then use a voltmeter or oscilloscope to monitor the output of the injection transformer and adjust the gain knob on the power amplifier for the desired output value. This can be done before power is applied; in fact it can be done before the injection transformer is even connected into the circuit. For example, let's say you are



testing the impedance of some piece of the International Space Station. The Space Station power bus is 120 VDC and program officials have decided that a 2% variation in the power bus will not damage the equipment. That means that the 120 VDC bus can vary by  $\pm 2.4$  volts and still be in the safe region. You can set the Model 3120 AC Volts Out to 1 volt peak. You can then monitor the output of the injection transformer and set the gain control of the power amplifier for  $\pm 2$  volts peak voltage at 1 kHz. This will give a small margin of safety (from 2 volts to 2.4 volts). The amplitude of the oscillator output is very flat with frequency. The gain of the power amplifier is also flat with frequency except where the output falls off, below 10 Hz and above 100 kHz. This means that by setting the amplitude in mid-range (1 kHz), the output amplitude will not exceed this value at any time during the sweep.

When you plot the test results, the variable called Scale Factor on the Data Set Properties window is the resistance used to measure the current or the effective resistance of the current probe. The polarity will be correct if the current probe arrow is pointing toward the Unit Under Test. If the current probe arrow is pointing away from the Unit Under Test, the Scale Factor will have to be entered as a negative value.

The graph below is actual test data of the input impedance of one of the Orbital Replacement Units of the International Space Station.

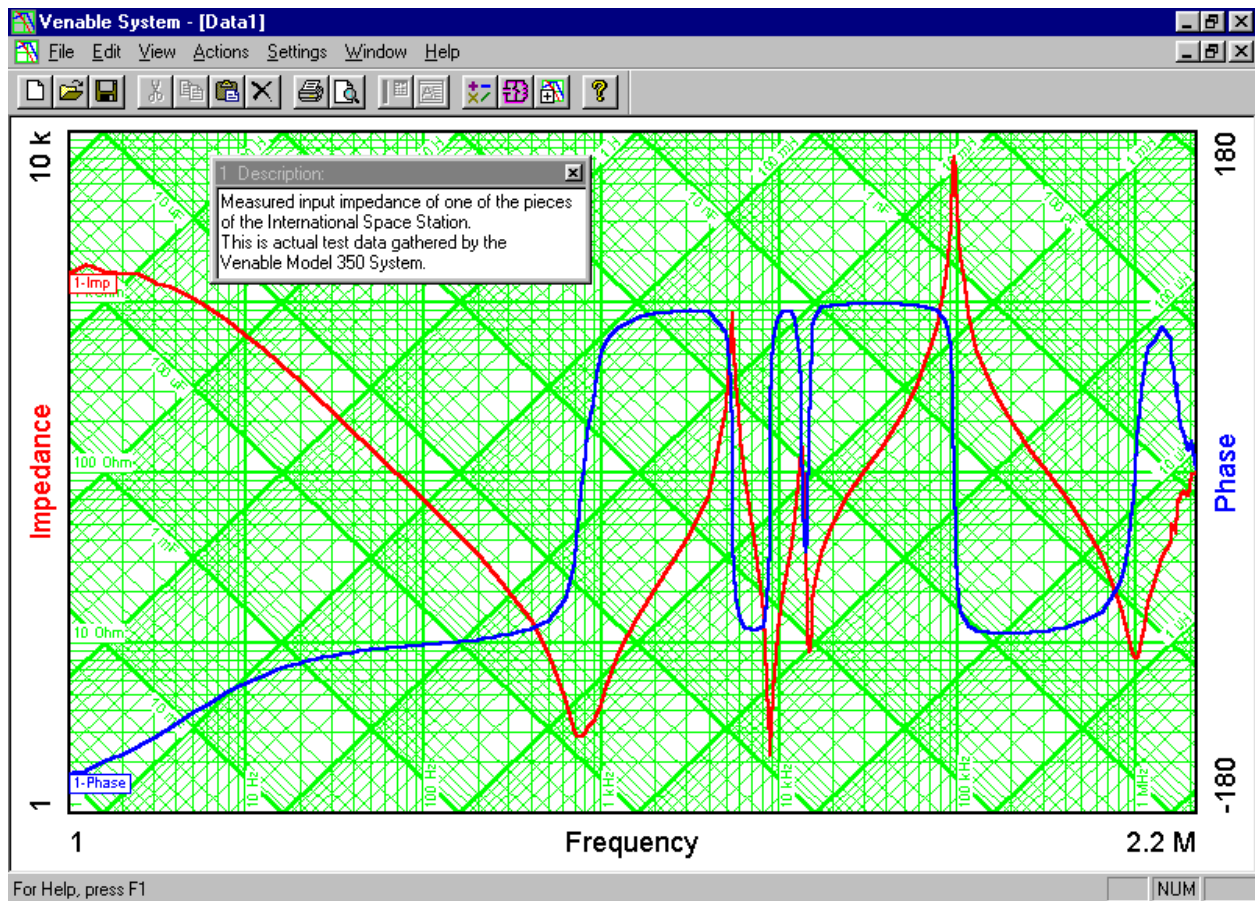

## Circuit Modeling Overview

### Introduction

The Venable software contains a built-in circuit-modeling program. This program is similar to SPICE in that it works from a net list. It is a relatively simple program. There are no libraries of parts and only AC analysis is performed. The advantage of this program is that it is very quick and easy to create and analyze models. It is easy to create accurate models of actual circuits since it is so easy to compare the model results with actual test results and also easy to change the model to make the model data match the test data.

We recognize that keying in a few lines of circuit description is not as glamorous as entering data with a schematic entry program, but we think you will find this method quicker and easier once you get used to it.

### The following components are available:

V	Voltage source (volts)
I	Current source (amps)
R	Resistor (ohms)
L	Inductor (henries)
C	Capacitor (farads)
G	Conductance (mhos)

You can add annotation after any component designator. V, V213, or Vemf all will be interpreted as a voltage source.

### The following abbreviations can be used for multipliers:

p or P	multiplied by 1E-12
n or N	multiplied by 1E-9
u or U	multiplied by 1E-6
m	multiplied by 1E-3
k or K	multiplied by 1E+3
M	multiplied by 1E+6
g or G	multiplied by 1E+9

**The format of a source is:**

<i>Type of source</i>	<i>positive control node</i>	<i>negative control node</i>	<i>value or gain</i>
<i>Resistance</i>	<i>positive connection node</i>	<i>negative connection node</i>	<i>value</i>

A special case is using 0 for both control nodes; this indicates a fixed source.

Spaces or commas separate entries.

**Example 1: Voltage Source**

```
V 0 0 1
R 1 0 50
```

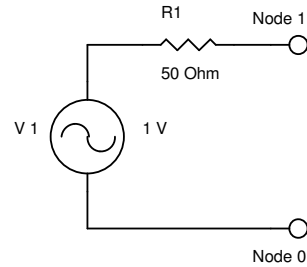

This is a fixed 1-volt source with an impedance of 50 ohms, connected in the circuit from node 1 (positive node) to node 0 (negative node). Node 0 is always circuit common.

**Example 2: Current Source**

```
I 3 4 0.1
R 2 0 1M
```

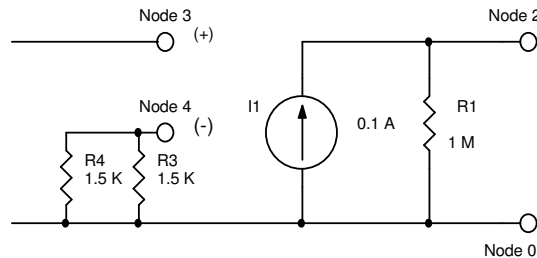

This is a current source controlled by the voltage from node 3 to node 4. It has a gain of 0.1, which means 1 volt from node 3 to node 4 will produce 0.1 amp from this source. It is connected in the circuit from node 2 to node 0, and is paralleled by a 1 mega-ohm resistor. Node 2 is in phase with node 3.

**The format of a component is:**

<i>Component type</i>	<i>connection node</i>	<i>connection node</i>	<i>value</i>
-----------------------	------------------------	------------------------	--------------

**Example 3: Component (in this case, a capacitor)**

```
C13 4 3 10U
```

This is a capacitor connected from node 4 to node 3 with a value of 10 microfarads. The order of the connection nodes is not significant. The number "13" after the C is any desired notation to identify the component, usually the reference designator.



## Notes on model file creation:

Model files are ordinary ASCII text files. They can be created with any ASCII editing program such as Notepad in Windows.

Model files can have any extension, but if they have no extension a .CKT extension will be added when the circuit is saved.

Comment lines can be added at the beginning of a file by beginning each line with an asterisk.

Comments can be added at the end of any line. It is not necessary to begin a comment with an asterisk. The program will ignore anything on a line after reading the required four entries.

Blank lines are ignored.

Circuit node numbers must be sequential. They do not have to be entered in sequence, but all nodes from 0 to the highest number node must be present. A missing node number will generate an error.

### Example 4: Circuit file for a low-pass filter

\*Low-pass R-C filter

```
V1 0 0 1
```

```
R1 1 0 1
```

```
R2 1 2 1K
```

```
C1 2 0 0.1U
```

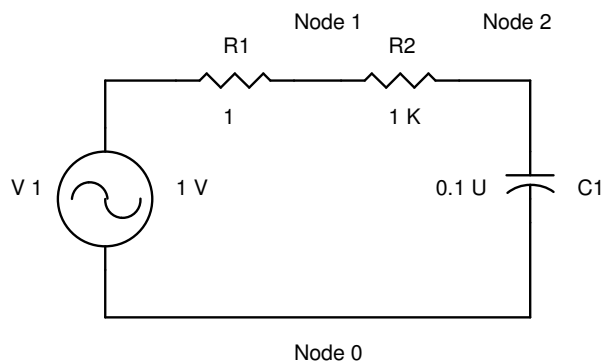

This circuit file represents a fixed one-volt source with a source impedance of 1 ohm driving a low-pass filter consisting of a 1,000 ohm resistor in series with a 0.1 microfarad capacitor to ground. When analyzed and plotted as the transfer function (Bode plot) from node 1 to node 2, the result will be a classic low-pass filter response. Since the result is plotted as the ratio of the voltage on node 2 divided by the voltage on node 1, the impedance of the source (1 ohm) does not enter into the calculation and the result will be the same no matter what the value of the source resistance.

## Example 5: Measuring the output impedance of an input filter

\*Model of input filter output impedance

V1 3 2 10 Controlled source translates current to ground reference. Gain=1/R3.  
 R1 1 0 1 Resistance of controlled source (value not significant)  
 V2 0 0 1 Fixed one volt source driving output of filter  
 R2 3 0 1 Impedance of test source (value not significant)  
 R3 3 2 0.1 Resistor to measure current. Different value changes gain of V1.  
 C1 2 4 100U Output capacitance of L-C filter  
 R4 4 0 0.01 ESR of filter output capacitor  
 R5 2 5 2 Damping resistor  
 C2 5 0 390U Capacitor to block DC current through damping resistor  
 L1 2 6 100U Input inductance of L-C filter  
 R6 6 0 0.01 Resistance of input inductor

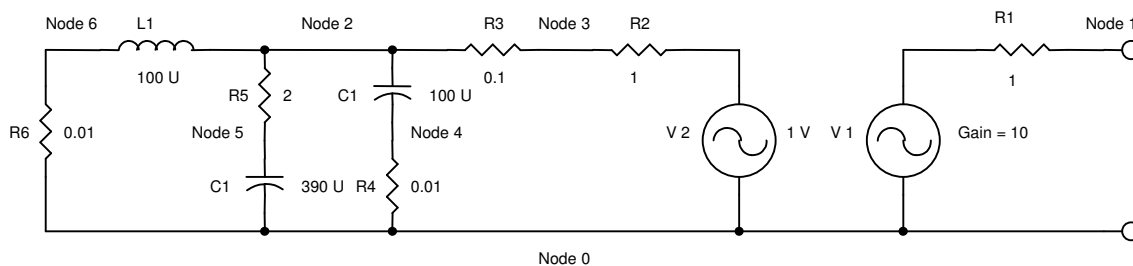

Normally R3 would be 1 ohm to simplify the calculation, and V1 would have a gain of 1. The values used in this example show the flexibility of the technique.

R6 is connected to ground to represent zero AC impedance of the power source.

In this example, filter impedance is measured as Node 2 over Node 1.

Note that the Venable system, unlike older Spice-type modeling programs, actually plots the ratio of the output to the input. Many older modeling programs require a one-volt source as an input and then plot absolute value of the output and pretend it is the ratio of output to input. This works when the input is exactly one volt, but the technique falls apart when the input is not one volt. When measuring gain by plotting the ratio of voltages on each side of an injection resistor, the capability to plot voltage ratios is essential.